

TECHNICAL MANUAL

**OPERATOR, UNIT, DIRECT SUPPORT
AND GENERAL SUPPORT MAINTENANCE MANUAL
(INCLUDING REPAIR PARTS AND SPECIAL TOOLS LIST)**

**MELTER, ASPHALT, SKID MOUNTED
HOT OIL CIRCULATING, 750 GPH
CHAUSSE MODEL STMD-3000A
(NSN 3895-01-332-3024)
END ITEM CODE (EIC): E4Y**

Contract No. DAAE07-90-C-1294

Approved for public release; distribution is unlimited

*** This manual supersedes TM 5-3895-368-14&P, dtd November 1992**

HEADQUARTERS, DEPARTMENT OF THE ARMY

15 FEBRUARY 1996

WARNINGS

- **DO NOT OPERATE ASPHALT MELTER WITHOUT PROTECTIVE, INSULATED CLOTHING, PARTICULARLY GLOVES. HIGH OPERATING TEMPERATURE OF HEAT TRANSFER OIL PIPING AND ASPHALT MELTER MAY CAUSE SEVERE BURNS BY GRABBING OR LEANING ON EQUIPMENT.**
- **DO NOT OPERATE UNIT IN THE RAIN. OPERATION OF THE ASPHALT MELTER DURING RAIN MAY CAUSE THE ASPHALT TO BOIL AND CATCH FIRE. AFTER A RAIN OR DURING HUMID CONDITIONS, OPEN THE TUNNEL DOORS AND DRY UNIT BEFORE OPERATING. KEEP THE HEAT TRANSFER PIPING SYSTEM FULL TO MINIMIZE CONDENSATION.**
- **DURING OPERATION, ASSOCIATED EQUIPMENT TO THE MELTER, (GENERATOR, HOT OIL HEATER) PRODUCE NOISE LEVELS THAT EXCEED 85 DECIBELS (dB). SEVERE HEARING IMPAIRMENT CAN RESULT IF HEARING PROTECTION DEVICES ARE NOT WORN.**
- **CHECK WITH LOCAL SAFETY OFFICE FOR CONFINED SPACE ENTRY REQUIREMENTS. ENTRY INTO A CONFINED SPACE IS PROHIBITED UNTIL A DETERMINATION IS MADE THAT THE SPACE IS NOT A HAZARDOUS ATMOSPHERE. ENTRY OF PERSONNEL BELOW DIRECT SUPPORT FOR MAINTENANCE PURPOSES IS PROHIBITED. FAILURE TO COMPLY CAN CAUSE INJURY TO PERSONNEL DUE TO OXYGEN DEFICIENCY, CHEMICAL CONTAMINANTS AND EXTREME TEMPERATURE IN BOTH THE TANK AND TUNNEL OF THE MELTER.**
- **ALLOW UNIT TO COOL TO AMBIENT TEMPERATURE BEFORE STARTING CLEANING OPERATIONS OR DISMANTLING OF UNIT. UNIT OPERATES AT 2350F, SEVERE BURNS MAY RESULT IF CONTACT IS MADE WITH UNIT.**
- **TUNNEL MUST BE REMOVED A MINIMUM OF 24 HOURS PRIOR TO ENTRY OF STORAGE TANK. CHEMICAL CONTAMINANTS MAY BE PRESENT, AND MAY CAUSE SICKNESS OR IRRITATION.**
- **PERSONNEL REQUIRED TO PERFORM MAINTENANCE WORK WITHIN THE TUNNEL OR TANK MUST BE DONE BY, OR IN THE PRESENCE OF, AT LEAST TWO PERSONS TRAINED IN CONFINED SPACE ENTRY.**
- **THE ATMOSPHERE WITHIN THE TANK AND TUNNEL MUST BE CHECKED PRIOR TO ENTRY. OXYGEN LEVEL MUST BE SAFE BEFORE ANY ACCURATE EXPLOSIVE MEASUREMENTS CAN BE TAKEN. THE ATMOSPHERE WITHIN THE TANK AND TUNNEL MUST BE TESTED WITH A CALIBRATED DIRECT READING INSTRUMENT FOR THE FOLLOWING CONDITIONS IN THE ORDER GIVEN: A. OXYGEN CONTENT, B. FLAMMABLE GASES AND VAPORS, C. POTENTIAL TOXIC AIR CONTAMINANTS.**

WARNINGS

- **OPERATOR PERSONNEL ARE REQUIRED TO WEAR PERSONAL PROTECTIVE EQUIPMENT WHILE WORKING WITH HOT ASPHALT. A FULL FACE SHIELD, LEATHER OR RUBBER SAFETY SHOES, HEAVY INSULATED GLOVES, AND CLOTHING COVERING ALL EXPOSED SKIN ON ARMS AND LEGS.**
- **DRY-CLEANING SOLVENT (P-D-680) CONTAINS PETROLEUM DISTILLATES AND IS TOXIC AND FLAMMABLE. WEAR PROTECTIVE GOGGLES AND BUTYL RUBBER GLOVES; USE ONLY IN A WELL-VENTILATED AREA; AVOID CONTACT WITH SKIN, EYES, AND CLOTHES AND DO NOT BREATHE VAPORS. KEEP AWAY FROM HEAT OR FLAME. NEVER SMOKE WHEN USING SOLVENT, THE FLASH POINT FOR TYPE I DRY-CLEANING SOLVENT IS 100°F (38°C), FOR TYPE II IS 138°F (50°C), AND FOR TYPE III IS 200°F (94°C). FAILURE TO DO SO MAY RESULT IN INJURY OR DEATH TO PERSONNEL. CONSULT THE PRODUCT MATERIAL SAFETY DATA SHEET OR THE PRODUCT MANUFACTURER FOR ADDITIONAL PRODUCT INFORMATION. KEEP THIS INFORMATION IN MIND WHEN A WARNING FOR USE OF P-D-680 IS SEEN IN THIS MANUAL.**
- **IF PERSONNEL BECOME DIZZY WHILE USING CLEANING SOLVENT, IMMEDIATELY GET FRESH AIR AND MEDICAL HELP. IF SOLVENT CONTACTS EYES, FLUSH EYES WITH WATER AND GET IMMEDIATE MEDICAL ATTENTION.**
- **WHEN OPENING THE DOORS, ALWAYS CHECK THAT THE RATCHET LOCK IS SET AND HOLDING BEFORE RELEASING THE WINCH HANDLE. INJURY TO PERSONNEL MAY RESULT IF DOOR SHOULD DROP UNEXPECTEDLY.**
- **EYE PROTECTION MUST BE WORN WHEN GRINDING OR CUTTING CHAIN. FLYING PARTICLES CAN BE PRODUCED, WHICH CAN CAUSE INJURY TO PERSONNEL.**
- **CAPACITOR MAY BE CHARGED. TO AVOID ELECTRICAL SHOCK, ENSURE THAT CAPACITOR HAS BEEN DISCHARGED BEFORE DISCONNECTING WIRE LEADS.**
- **ENSURE THAT THE ARMY "PREVENTIVE MEDICINE SERVICE" REVIEWS THE "MATERIAL SAFETY DATA SHEETS" FOR ALL FOREIGN MANUFACTURED ASPHALT PRODUCTS NOT IN THE ARMY SUPPLY SYSTEM BEFORE USING IN THE ASPHALT MELTER. TO IDENTIFY, EVALUATE, AND RECOMMEND METHODS TO CONTROL EXPOSURES TO ASPHALT COMPOUNDS NOT CONTAINED IN ARMY SUPPLIES ASPHALT.**

TECHNICAL MANUAL

No. 5-3895-368-14&P*

HEADQUARTERS
DEPARTMENT OF THE ARMY
Washington, DC, 15 February 1996

**TECHNICAL MANUAL
OPERATOR, UNIT, DIRECT SUPPORT AND
GENERAL SUPPORT MAINTENANCE MANUAL
(INCLUDING REPAIR PARTS AND SPECIAL TOOLS LIST)**

**MELTER, ASPHALT, SKID MOUNTED
HOT OIL CIRCULATING, 750 GPH
CHAUSSE MODEL STMD-3000A
(NSN 3895-01-332-3024)
END ITEM CODE (EIC): E4Y**

Contract DAAE07-90-C-1294

Current as of 19 December 1995

REPORTING ERRORS AND RECOMMENDING IMPROVEMENTS

You can help improve this manual. If you find any mistakes, or if you know of a way to improve the procedures, please let us know. Mail your letter, DA Form 2028 (Recommended changes to Publications and Blank Forms), or DA Form 2028-2, located in the back of this manual direct to Commander, US Army Tank-automotive and Armament Command, ATTN: AMSTA-IM-MMAA, Warren MI 48937-5000. A reply will be sent to you.

Portions of this technical manual are an authentication of the manufacturers commercial literature and does not conform with the format and content specified in AR 25-30, Military Publications. This technical manual does, however contain available information that is essential to the operation and maintenance of the equipment.

Approved for public release; distribution is unlimited

*** This manual supersedes TM 5-3895-368-14&P, dtd November 1992**

TABLE OF CONTENTS

		Page
Section I. INTRODUCTION		
Para.	1-1. Description.....	1-1
	1-2. Tabulated Data.....	1-1
	1-3. Safety Precautions.....	1-1
Section II. INSTALLATION		
Para.	2-1. General.....	2-1
	2-2. Site Preparation.....	2-1
	2-3. Unpacking.....	2-1
	2-4. Installation.....	2-4
Section III. OPERATING INSTRUCTIONS		
Para.	3-1. Controls and Instruments	3-1
	3-2. Initial Start-Up.....	3-2
	3-3. Operating Instructions	3-3
	3-4. Shutdown Instructions	3-3
Section IV. MAINTENANCE INSTRUCTIONS		
Para.	4-1. Cleaning Instructions	4-1
	4-2. Lubrication Instructions.....	4-1
	4-3. Maintenance Instructions.....	4-1
	4-4. Winch Repair Instructions	4-3
	4-5. Electric Hoist Repair Instructions.....	4-5
Section V. PREPARATION FOR SHIPMENT OR STORAGE		
Para.	5-1. Preparation for Shipment.....	5-1
	5-2. Transporting	5-2
	5-3. Storage	5-3
Appendix A. UNIT, DIRECT SUPPORT, AND GENERAL SUPPORT MAINTENANCE		
REPAIR PARTS AND SPECIAL TOOLS LIST		A-1
Figure	1. Accessory Items, Asphalt Hose.....	1-1
	2. Plate/Decal Installation	2-1
	3. Thermometer	3-1
	4. Dedrumming Tunnel and Guards	4-1
	5. Loading Platform	5-1
	6. Upper Structure, Loading Platform	6-1
	7. Guard Rails.....	7-1
	8. Discharge Chute.....	8-1
	9. Valves and Hot Oil Piping.....	9-1
	10. Connecting Hot Oil Piping.....	10-1
	11. Storage Tank and Pipe Coils.....	11-1
	12. Electric Hoist Installation	12-1
	13. Electric Hoist, Motor End	13-1
	14. Electric Hoist, Gears and Hooks	14-1
	15. Electric Hoist, Brake End.....	15-1
	16. Electric Hoist, Controller	16-1
	17. Trolley Assembly, Hoist.....	17-1
	18. Winch Assembly	18-1
Appendix B. SUPPLEMENTAL OPERATION, MAINTENANCE AND REPAIR PARTS		
INSTRUCTIONS		B-1
Appendix C. WARRANTY PROGRAM		
		C-1
Appendix D. MAINTENANCE ALLOCATION CHART.....		
		D-1
Appendix E. PREVENTIVE MAINTENANCE CHECKS & SERVICES		
		E-1
Appendix F. COMPONENTS OF END ITEM (COEI) and BASIC ISSUE ITEMS LIST (BIIL).....		
		F-1
Appendix G. ILLUSTRATED LIST OF MANUFACTURED ITEMS.....		
		G-1

Section I. - INTRODUCTION

1-1. Description.

a. This manual provides instructions for operation and service and lists repair parts for the Chausse Model STMD-3000A, asphalt de-drumming melter, manufactured by Chausse Manufacturing Co., Inc. The unit consists of a de-drumming tunnel and a 3000 gallon capacity, heated storage tank. The tunnel is constructed to handle a maximum of six, 55 gallon drums at one time, with a melting rate of 750 gallons per hour of 85-100 penetration asphalt cement. The melted cement can be maintained in the storage tank at pouring temperature (235°F.), and transferred to bulk storage tanks or distributors by means of a separately supplied asphalt pump. Figure 1-1, identifies major components and features of the melter in its basic operating configuration.

b. The tunnel and storage tank are equipped with heat dissipating coiled piping, interconnected with removable external piping and valves to permit control of heat transfer medium. A separately supplied heat supply must provide 1, 000, 000 BTU per hour to the melter. Circulating hot oil is recommended as the most efficient heat transfer medium. When oil is not available, hot water or steam can be substituted, but only when proper safety devices are installed in the heat transfer piping system.

c. Attached to the front of the asphalt melter is a loading platform with an electric hoist to assist the operator in loading asphalt drums in the tunnel. A ladder provides access to the load platform. A discharge chute is attached to the rear to receive empty drums. A gate on the bottom of the discharge chute holds the empty drums from one charge of the tunnel, allowing controlled removal of empty drums.

d. Right and left sides of the melter are determined by standing at the rear of the melter, looking forward.

1-2. Tabulated Data.

Model	STMD-3000A
De-drumming Rate	750 GPH
Tunnel Capacity	6 - 55 Gal. Drums
Storage Tank Capacity	3000 Gal.
Hoist Capacity	1000 pounds
Heat Requirement	1,000,000 BTU/Hr.
Heat Transfer Piping	2 inch
Asphalt Piping	3 inch
Shipping Dimensions:	

Height	102 inches
Width	79 inches
Length	209 inches
Weight (Clean)	12, 100 pounds
Operating Dimensions:	
Height (Top of tunnel).....	145.75 inches
(Top of hoist)	155 inches
(Drum loading platform)....	75 inches
Width	91 inches
Length	370 inches
Weight (Clean)	12, 100 pounds

1-3. Safety Precautions.

a. When lifting unit in shipping configuration, do not use lifting eyes of tunnel. Attach lifting sling to eyes in ends of skid rails and guide sling cables over the stand-off guard at front and rear of unit.

b. Operator must wear Personal Protective Equipment while working with hot asphalt. Full face shield, leather or rubber safety shoes, heavy insulated gloves, and protective clothing such as coveralls covering all exposed skin on arms and legs.

c. Do not operate unit in the rain. Operation of melter during rain may cause the asphalt to boil and catch fire. After a rain or during humid conditions, open the tunnel doors and dry the unit before operating. Keep the heat transfer piping system full to minimize condensation.

d. Keep an accurate record of the amount of asphalt that is de-drummed. Do not overfill the storage tank, maximum capacity is 3000 gallons.

e. Allow unit to cool to ambient temperature before starting cleaning operations or dismantling of unit.

f. Use only approved type solvents. Do not use gasoline or diesel fuel to clean equipment parts, clothing, floors, etc., or for any cleaning purposes.

g. During operation, associated equipment to the melter, (generator, hot oil heater) produce noise levels that exceed 85 dB. Wear approved hearing protection devices.

h. When using hoist: do not lift more than rated load; do not pull load at an angle, be sure hoist and load are in a straight line; do not operate a damaged or malfunctioning hoist; do not operate hoist with twisted, kinked or damaged chain.

i. Do not lift personnel with hoist, or lift load over personnel.

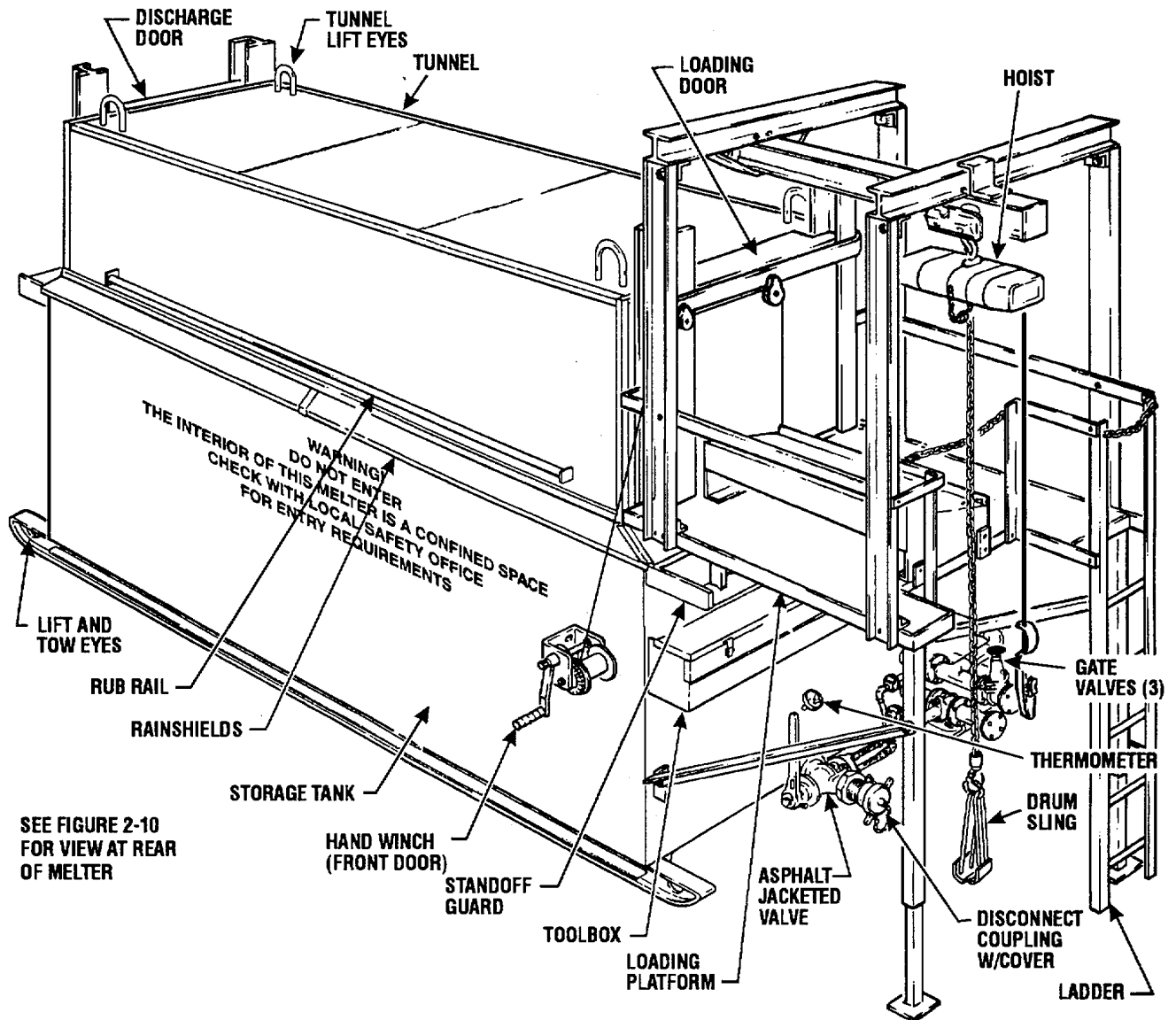

Figure 1-1. Asphalt Melter, Model STMD-3000A, right front, three-quarter view.

j. Insure that equipment is operated in a well ventilated area. Associated equipment to the melter, (generator, hot oil heater) produce exhaust emissions that can cause brain damage or death from heavy exposure.

k. Entry into a confined space is prohibited until a determination is made that the space is not a hazardous

atmosphere. Entry of personnel below Direct Support for maintenance purposes is prohibited. Failure to comply can cause injury to personnel due to oxygen deficiency, chemical contaminants and extreme temperature in both the tank and tunnel of the melter.

l. All maintenance on the tank and tunnel should be performed outside whenever possible.

Section II. - INSTALLATION

2-1. General.

The asphalt melter unit may be installed as a single unit where job requirements call for 750 gallons or less, of asphalt cement per hour. Where job requirements in excess of 750 gallons per hour exist, two units may be interconnected in parallel, with piping provided with each unit.

2-2. Site Preparation.

a. The asphalt melter must be installed on a solid, level and well drained base or concrete pad. The minimum area required for installation of the asphalt melter is 10 x 32 feet.

b. Site planning must also provide for positioning of the asphalt melter(s), the heat plant and the asphalt pumping unit so that sufficient additional space is available at the front and rear of the melter(s) for loading and unloading of drums.

c. When installing two or more units in parallel, the site must provide for spacing of the asphalt melters, four feet apart (measured between outside walls of storage tanks) to align and install interconnect piping.

2-3. Unpacking.

a. The asphalt melter is shipped as a self-contained unit, requiring unpacking and set-up before operation can begin.

b. A suitable lifting device, of sufficient capacity, (approximately 12, 100 lbs.) must be available for unloading, unpacking and set-up of the asphalt melter. Remove all tiedown cables or strapping and all blocking used to secure the unit to the carrier.

CAUTION

DO NOT attach lifting sling to lift eyes on top of tunnel or to the stand-off guards at front and rear of unit. Attach lifting sling to eyes in the front and rear of the skid rails, guiding the sling cables over the stand-off guards at each end of unit.

c. Attach a suitable lifting sling to the eyes of skid rails, with cables guided over the top of the stand-off

guards at front and rear of the unit. Lift the unit from the carrier bed and position unit on worksite.

NOTE

The asphalt melter may be moved short distances on its skid rails by attaching towing chains to the eyes in the front or rear skid rails.

d. Remove strapping securing the discharge chute and load platform to the top of the asphalt melter tunnel. Attach a four-point sling to the discharge chute and lift the chute clear of the tunnel with a suitable lifting device and set the chute on the ground clear of the melter installation area.

e. Attach a four-point sling to the load platform and lift the platform from the top of the tunnel and set the platform on the ground clear of the melter installation area.

f. Remove the four holddown bars, securing the tunnel support beams to the storage tank (Figure 2-1). Lift out the two tunnel support beams.

g. Attach a four-point sling to the lifting eyes on top of the tunnel and lift (approximately 5000 lbs.) the tunnel out of the storage tank with a suitable lifting device. Place the tunnel on wood blocks, positioned to support the tunnel support rails.

h. Check inside of storage tank and remove any parts or foreign material that may have fallen in.

i. Re-install the tunnel support beams in the storage tank, securing with the holddown bars.

j. Open the tunnel doors and secure with blocking. Remove storage crate, ladder, load ramp, trolley, and electric hoist. Remove items listed in Table 2-1 from crate; retain crate for future storage and transportation.

NOTE

If any items, listed in Table 2-1 or paragraph j, are not found inside the tunnel, check the toolbox. Report missing items to Unit Maintenance.

k. Open the toolbox and remove the items listed in Table 2-2. Report missing or damaged parts to Unit Maintenance.

Table 2-1. Loose Items Shipped Crated Inside Tunnel.

PART NO.	DESCRIPTION	QTY	FIG/INDEX NO.
3000-9	Flex-hose, asphalt	1	2-5-3
3000-10	Reducer, tee	2	2-5-7
3000-11	Connector pipe	1	2-6-12
3000-12	Shield front rain	1	2-3-3
3000-13	Shield, LH forward side rain	1	2-3-4
3000-14	Shield, RH forward side rain.....	1	2-3-5
3000-15	Shield, LH rear side rain.....	1	2-3-11
3000-16	Shield, RH rear side rain	1	2-3-12
3000-17	Shield, rear rain	1	2-3-13
3000-113	Support, Up-right	4	2-8-6
3000-114	Cross beam, front.....	1	2-8-4
3000-115	Cross beam, rear	1	2-8-1
3000-116	Rail, trolley.....	1	2-8-5
3000-118	Railing corner, rear.....	2	2-9-3
3000-119	Railing, right side.....	1	2-9-11
3000-120	Railing, left side	1	2-9-7
3000-121	Railing, ladder	1	2-9-13
3000-122	Railing, front corner.....	1	2-9-8
3000-123	Support, railing front.....	1	2-9-9
3000-124	Support, railing right.....	1	2-9-10
3000-125	Support, railing left	1	2-9-12
3000-127	Brace, ladder	1	2-7-10
3000-129	Bracket, load ramp	2	2-7-2
3000-131	Brace, platform	2	2-7-12
3000-132	Leg, platform	2	2-7-6
3000-133	Leg extension, platform.....	2	2-7-11
3000-142	Barrel Ram	1	F-2, G
3000-143	Barrel extractor.....	1	F-1, G
MODEL 41	Sling, drum	1	2-12-3

Table 2-2. Loose Items Shipped In Toolbox.

PART NO.	DESCRIPTION	QTY	FIG/INDEX NO.
3000-4	Offset, inlet tee	1	2-4-6
3000-5	Inlet elbow, tunnel.....	1	2-4-2
3000-6	Gasket, 2 inch pipe ring.....	12	2-4-4
			2-5-8
488-1/2-2	Valve assembly, gate, 2 inch.....	3	2-4-7
3000-7	Offset, outlet, tee	1	2-4-22
3000-8	Outlet elbow, tunnel.....	1	2-4-19
T304SS-2	Union, pipe, stainless steel.....	2	2-4-1
245SS	Hose end, disconnect, 3 inch	2	2-5-1
MS90725-164	Screw, hex head cap, 5/8 NC x 2 inch long	24	2-4-3
MS90728-166	Screw, hex head cap, 5/8 NC x 2-1/2 inch long, grade 8.....	20	2-4-20
			2-5-10
MS90728-60	Screw, hex head cap, 3/8 NC x 1 inch long, grade 8.....	10	2-7-3
			2-9-14

Table 2-2. Loose Items Shipped in Toolbox - Continued.

PART NO.	DESCRIPTION	QTY	FIG/INDEX NO.
MS90728-64	Screw, hex head cap, 3/8 NC x 1-1/2 inch long, grade 8.....	35	2-7-9 2-8-7 2-9-6 2-11
MS90728-70	Screw, hex head cap, 3/8 NC x 3 inch long, grade 8.....	7	2-7-8
MS9072-162	Screw, hex head cap, 5/8 NC x 1-1/2 inch long, grade 8.....	4	2-8-10
MS51967-8	Nut, plain hex, 3/8 NC	52	2-7-4 2-8-2 2-9-5 2-11
MS51967-14	Nut, plain hex, 1/2 NC	2	2-9-2
MS51967-20	Nut, plain hex, 5/8 NC	52	2-4-5 2-4-21 2-5-11
MS35338-46	Washer, lock, 3/8 split	52	2-8-8 2-7-5 2-8-3 2-9-4 2-11
MS35338-48	Washer, lock, 1/2 split	2	2-9-1
MS35338-50	Washer, lock, 5/8 split	4	2-8-9
MS27183-14	Washer, flat, 3/8 inch	6	2-11
3465T27	Clip, wire rope.....	2	2-11
3000-144	Rope, wire	2	2-11
DLB 800	Winch, hand	2	2-11
Commercial	Plug, pipe, 2-1/2 NPT, square head.....	2	2-5-6
Commercial	Coupling, pipe, 3 NPT	1	2-5-2
Commercial	Tee, pipe, 3 NPT	1	2-5-4
Commercial	Plug, pipe, 3 NPT, square head	1	2-5-5
Commercial	Nipple, pipe, 3 NPT short	1	2-6-5

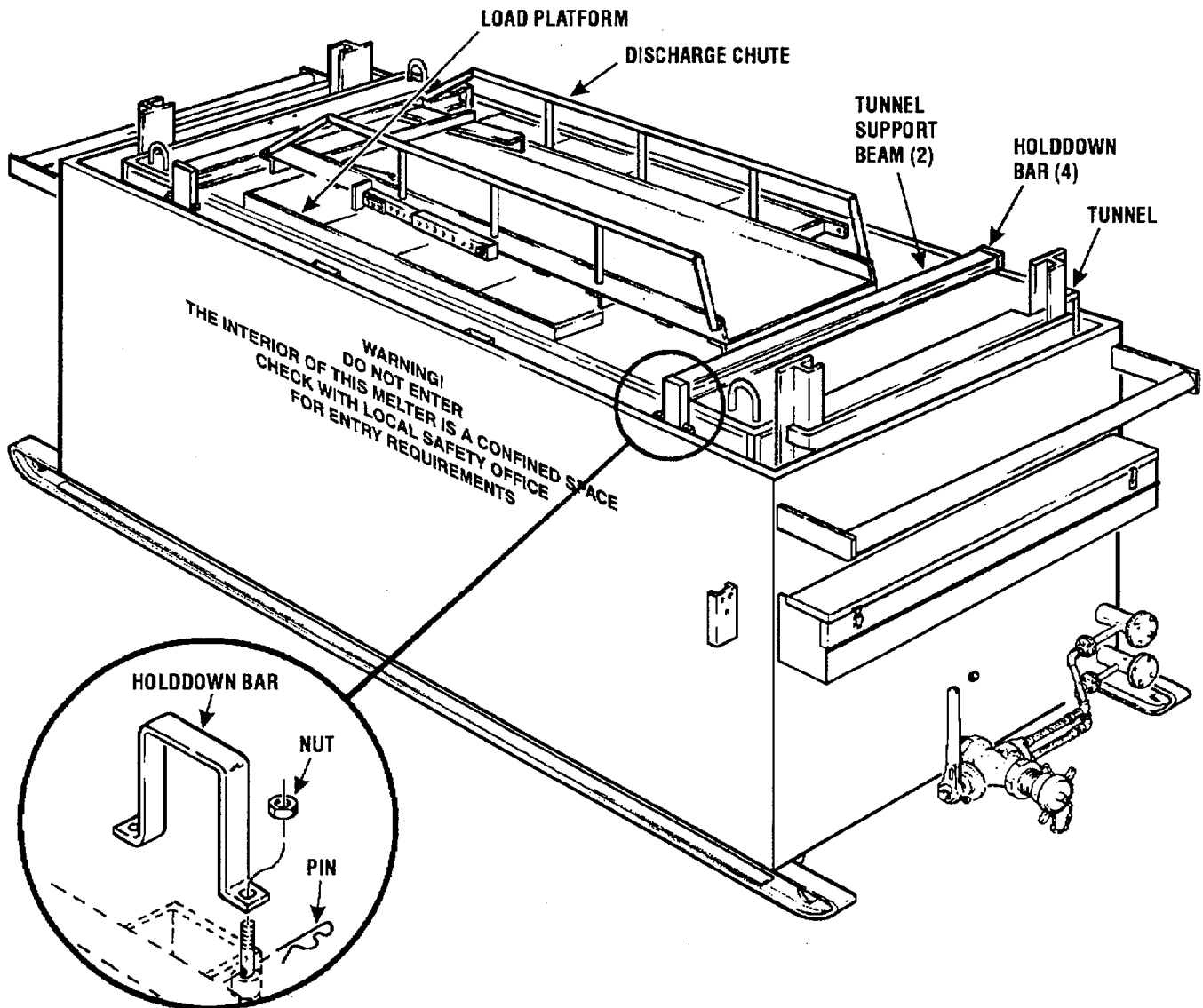

Figure 2-1. Asphalt Melter in Shipping Configuration.

2-4. Installation.

a. With a suitable hoist and a four-point sling attached to lifting eyes of tunnel, lift the tunnel into position over the storage tank. Align the tunnel so that the support rails (channels) on bottom of tunnel are directly over the tunnel support beams and lower the tunnel onto the beams. Center the tunnel between the sides of the storage tank.

NOTE

The front of the tunnel can be determined by looking at the cable pulleys welded to the support bar near top of door. The end of tunnel

with pulley on the left as you look at it is the front.

b. Install the six-piece rain shield around base of tunnel as shown in figure 2-2. The rear rain shield must be installed first, then the side rain shields, working from the rear forward, with the front rain shield (3, Figure 2-3) installed last.

c. Install thermometer (Figure 3-1) by threading into opening in front wall of storage tank.

d. Install heat transfer piping and asphalt jacketed valve as shown in figure 2-4. Insure that gaskets at each flanged coupling are not damaged or folded in such a way that would hinder sealing the joints.

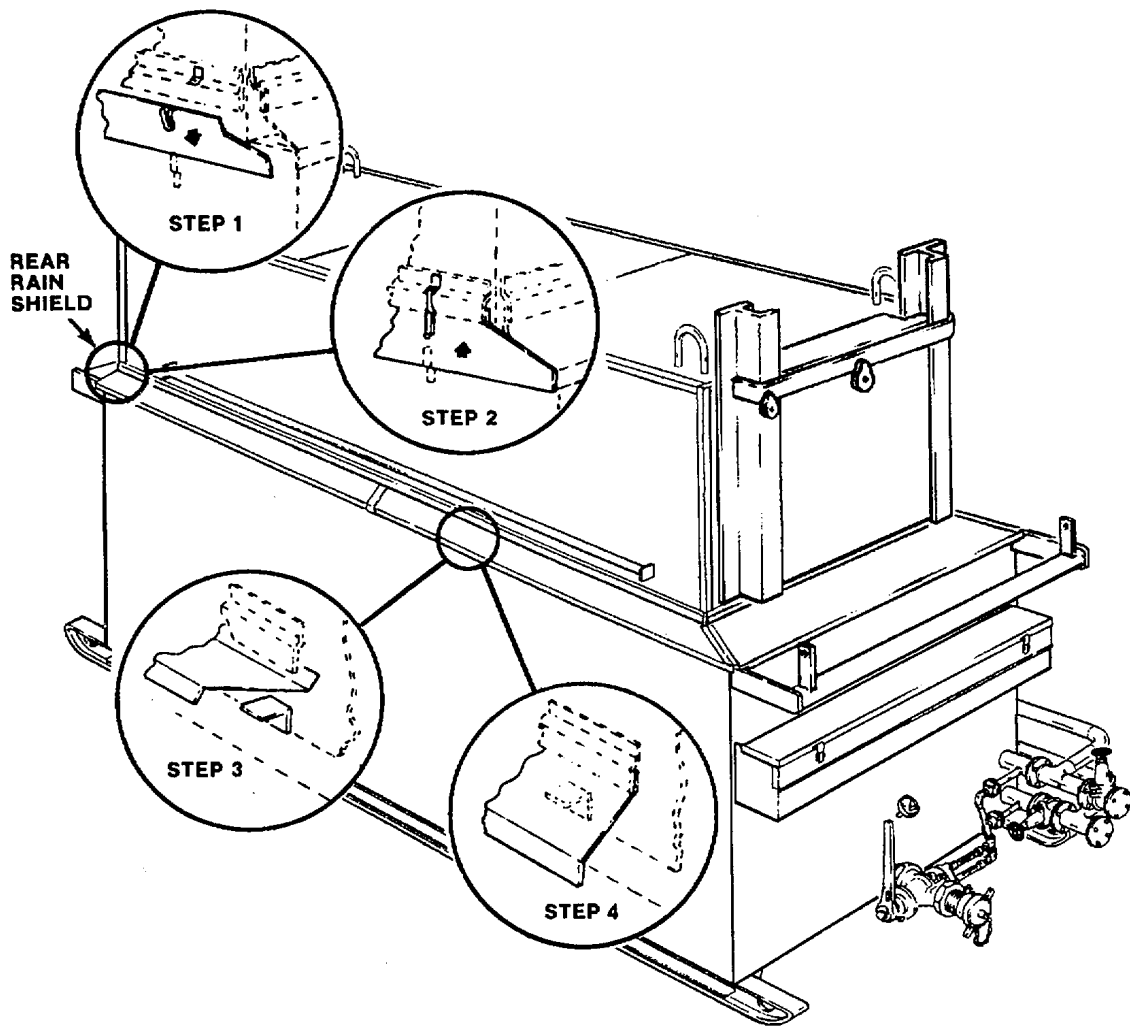

Figure 2-2. Installing Rain Shields.

NOTE

Install flange joint hexagon head capscrews and nuts finger tight, until all connections have been made then tighten all hardware securely.

e. For operation as a single unit installation, install connecting heat transfer piping and asphalt discharge hose as shown in figure 2-5.

f. For installations of multiple units make interconnections of heat transfer piping and asphalt hoses as shown in figure 2-6.

g. Inspect all connections to insure that they are tight and that the storage tank drain cap, in rear of storage tank, is installed.

h. Install load ramp (1, Figure 2-7), platform (13) and ladder (7) as shown in figure 2-7. Adjust leg extensions (11) so pads rest on ground or blocking while

keeping platform (13) as level as possible. Initially tighten all fasteners finger tight, when all adjustments and components are in place tighten fasteners securely.

i. Install the load platform upper-structure (Figure 2-8) as follows:

(1) Secure the up-right supports (6) to the load platform (13, Figure 2-7) noting that original supports were shipped with only one of the four drilled through the side flange. That support must be installed at the right-front position on the load platform.

(2) Carefully position the rear cross-beam (1, Figure 2-8) and front cross-beam (4) over up-rights (6) as shown with the mounting holes for the trolley rail (5) offset to the right side of the melter. Secure cross-beams with 5/8 inch capscrews (10), lockwashers (9), and nuts (8).

(3) Install trolley rail (5), securing with eight capscrews (7), lockwashers (3) and nuts (2). Be certain to install all eight capscrews with heads on the bottom side to clear the travel of the trolley on the trolley rail.

j. Install guard rails as shown on figure 2-9. The 1/2 inch nuts (2) and lockwashers (1) secure the rear rail corners (3) to studs welded to tunnel at each side of the front door frame. Tighten all hardware securely.

k. Install the rear discharge chute (Figure 2-10) by hooking angle on end of chute over the support angle welded to tunnel, just below the rear door frame. Lower the support legs and adjust the leg extensions as necessary to rest on ground.

l. Install the front and rear hand winches as follows:

- (1) Install the front winch (Figure 2-11) to channel on right side of storage tank. Secure with three capscrews, lockwashers and nuts.
- (2) Feed end of wire rope onto winch and secure with clamp as shown in figure 2-11.
- (3) Feed free end of wire rope through pulley #1, pulley #2, and pulley #3.
- (4) Loosen wire rope clip sufficiently to allow two strands of wire rope to be inserted. Feed free end of wire rope through clip around the door lift ring and loop back to pass through the clip a second time. Tighten the clip securely onto the wire rope.
- (5) Take up slack in wire rope by turning winch handle in a clockwise direction. Note that wire rope seats in groove of pulleys #1, #2, and #3.
- (6) Install the rear hand winch in a similar manner, noting that the winch mounts upside down compared to the front winch, and that pulley #1 is not used.

m. Assemble the trolley (1, Figure 2-12) onto the trolley rail as follows:

- (1) Remove one of the adjusting collars (Figure 2-13) by removing the cotter pin and clevis pin and sliding the adjusting collar off end of load bar.
- (2) Slide side #1 off the load bar, and position the load bar and assembled side #2 onto the flange of trolley beam. While holding that position install side #1 frame assembly onto the load bar (with "this side up" label on top).
- (3) Secure by installing the adjusting collar onto load bar and inserting clevis pin in the lower load bar pin hole. Adjust the collar as necessary to provide the clearance between load wheels and flange of trolley beam as shown in figure 2-13. Secure clevis pin after final adjustment with cotter pin.

NOTE

New trolley and trolley beam parts should normally be adjusted correctly when one collar is set to align with hole 'A' and the other collar aligned with hole "B". These hole identification letters are on the top flange of the collar directly above their hole.

n. Ensure that hoist chain is not twisted and attach hoist (2, Figure 2-12) to trolley by hooking with top hook on hoist. Attach drum sling (3) to bottom hook.

o. Plug power cord from hoist into an approved 110/120 volt power source.

p. Connect the heat transfer piping to the heat source at the 2-1/2 inch reducer coupling on the ends of connector pipes (7, Figure 2-5). Insure that the flow of heat transfer oil is as indicated on figure 3-1.

q. Connect the asphalt discharge hose to supplied pumping unit for transfer of melted asphalt to working distributor or bulk storage tank.

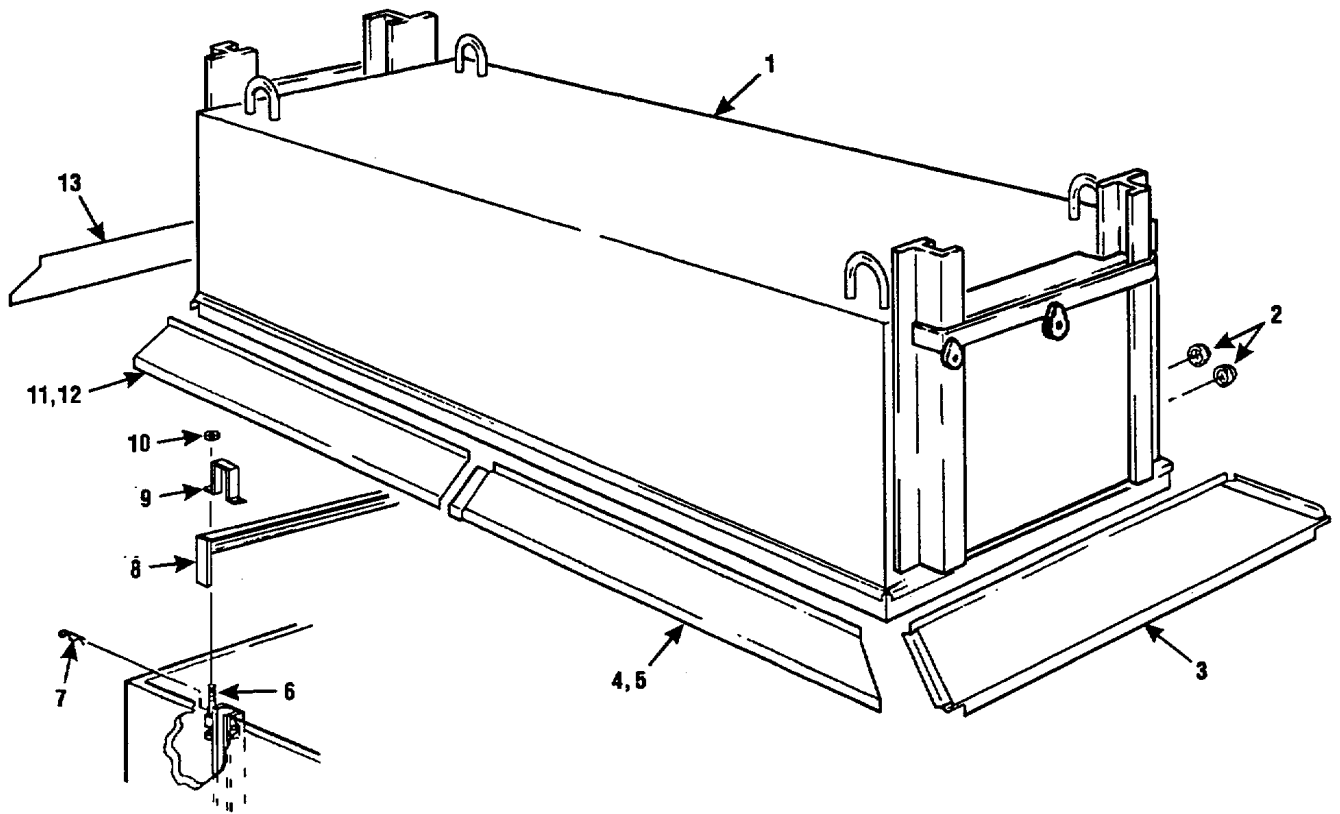

- | | | | |
|-------------------------|-------------------------|----------------------|-------------------------|
| 1. Tunnel | 5. Rainshield, LH Front | 8. Support Beam (2) | 11. Rainshield, RH Rear |
| 2. Pipe Cape (2) | 6. Bolt (8) | 9. Holddown Bar (\$) | 12. Rainshield, LH Rear |
| 3. Rainshield, Front | 7. Retainer Pin (8) | 10. Nut (8) | 13. Rainshield, Rear |
| 4. Rainshield, RH Front | | | |

Figure 2-3. Tunnel and Associated Parts.

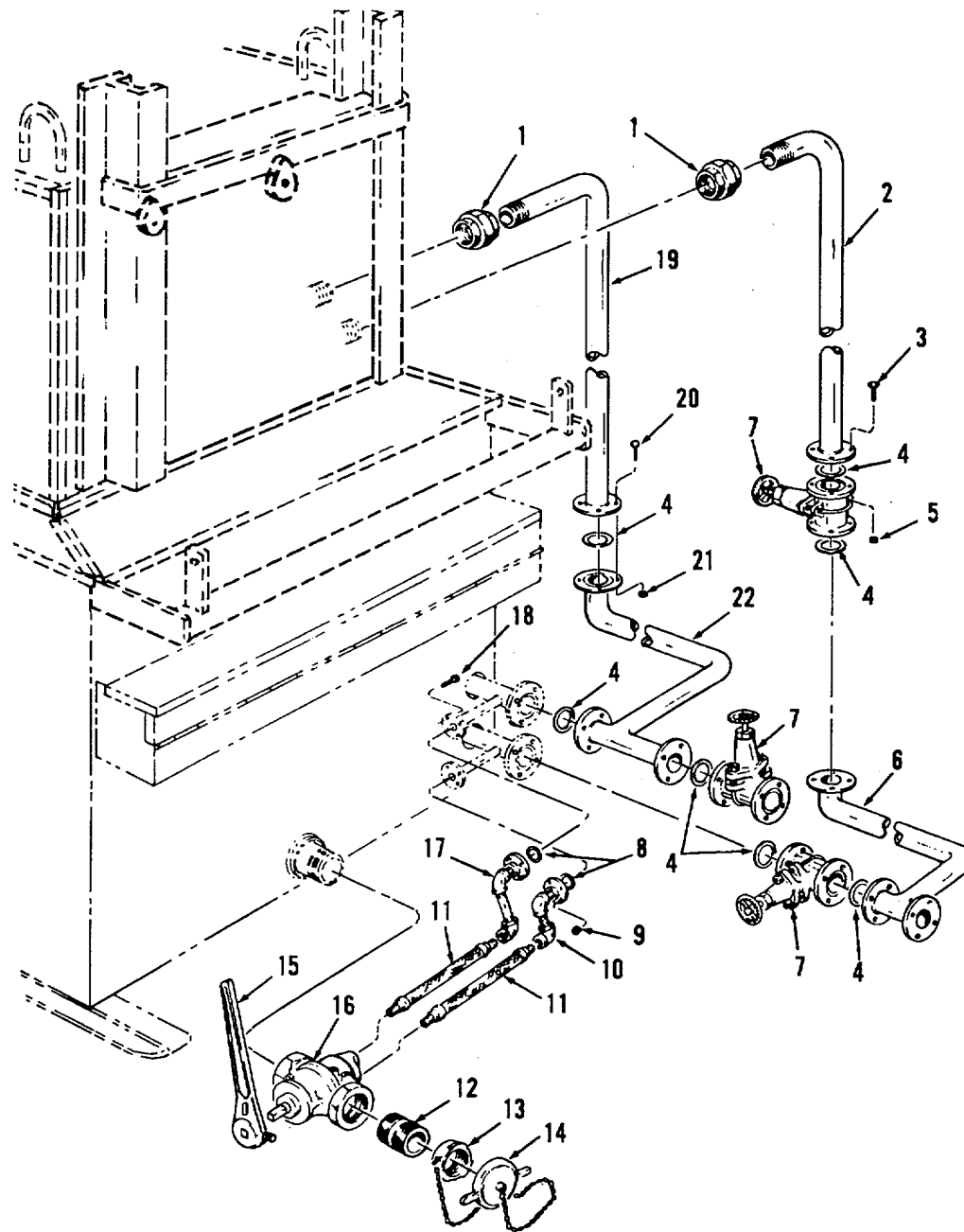

- | | | | |
|-----------------------------|-----------------------|-------------------|---------------------------------|
| 1. Union (2) | 6. Pipe Assembly | 12. Nipple | 18. Capscrew (8) |
| 2. Pipe Assembly | 7. Valve (3) | 13. Connector | 19. Pipe Assembly |
| 3. Capscrew, 5/8NC x 2 (20) | 8. Gasket (2) | 14. Cover | 20. Capscrew, 5/8NC x 2 1/2 (8) |
| 4. Gasket (7) | 9. Nut (8) | 15. Wrench | 21. Nut, 5/8NC (8) |
| 5. Nut, 5/8NC (20) | 10. Pipe Assembly | 16. Valve | 22. Pipe Assembly |
| | 11. Hose Assembly (2) | 17. Pipe Assembly | |

Figure 2-4. Asphalt Melter Basic Piping and Valve Installation.

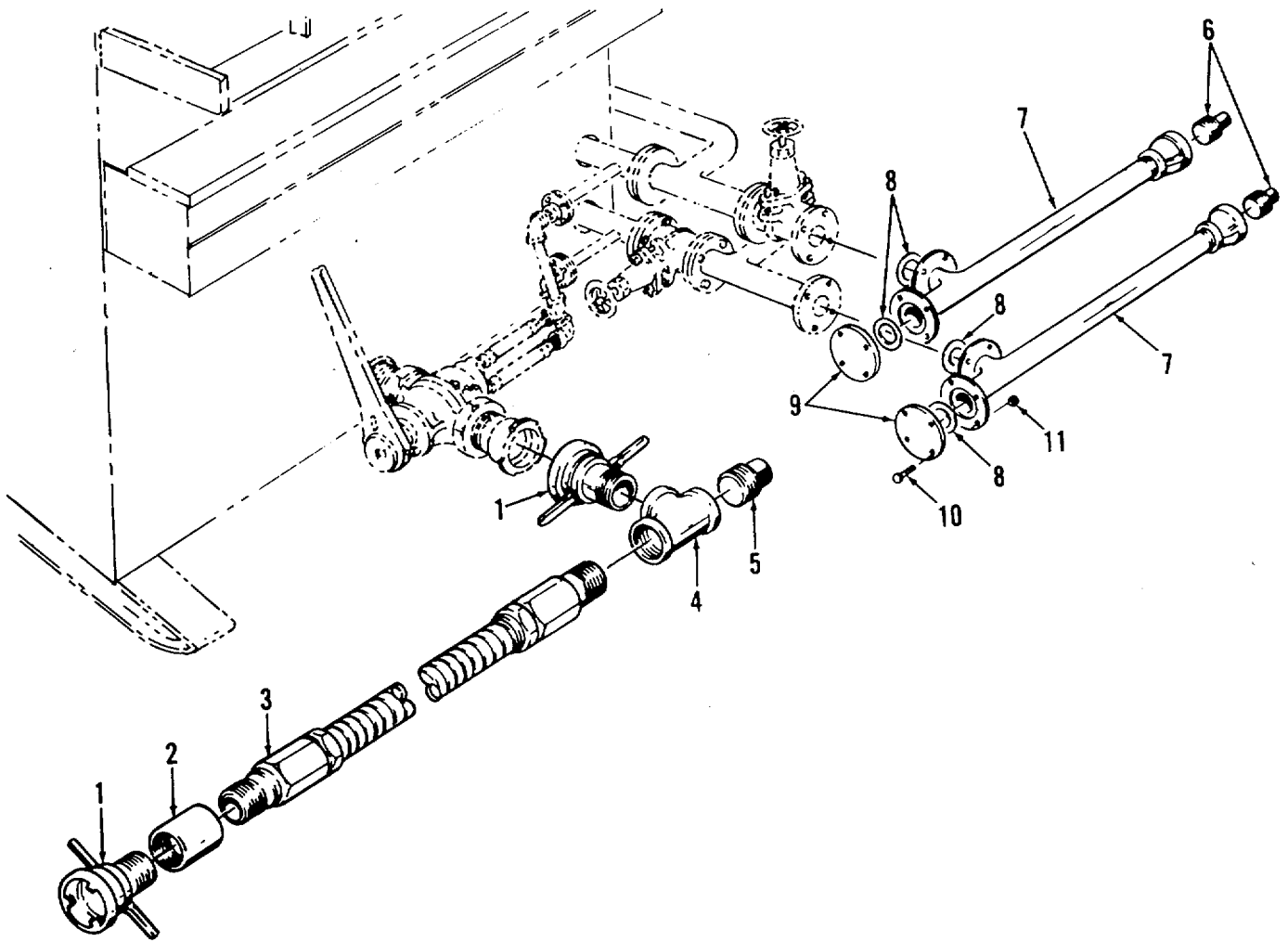

- 1. Connector (2)
- 2. Coupling
- 3. Hose

- 4. Tee
- 5. Plug
- 6. Plug (2)

- 7. Pipe Assembly (2)
- 8. Gasket (4)
- 9. Cover (2)

- 10. Capscrew, 5/8NC x 2 1/2 (16)
- 11. Nut, 5/8NC (16)

Figure 2-5. Hot Oil and Asphalt Piping for Single Unit Installation.

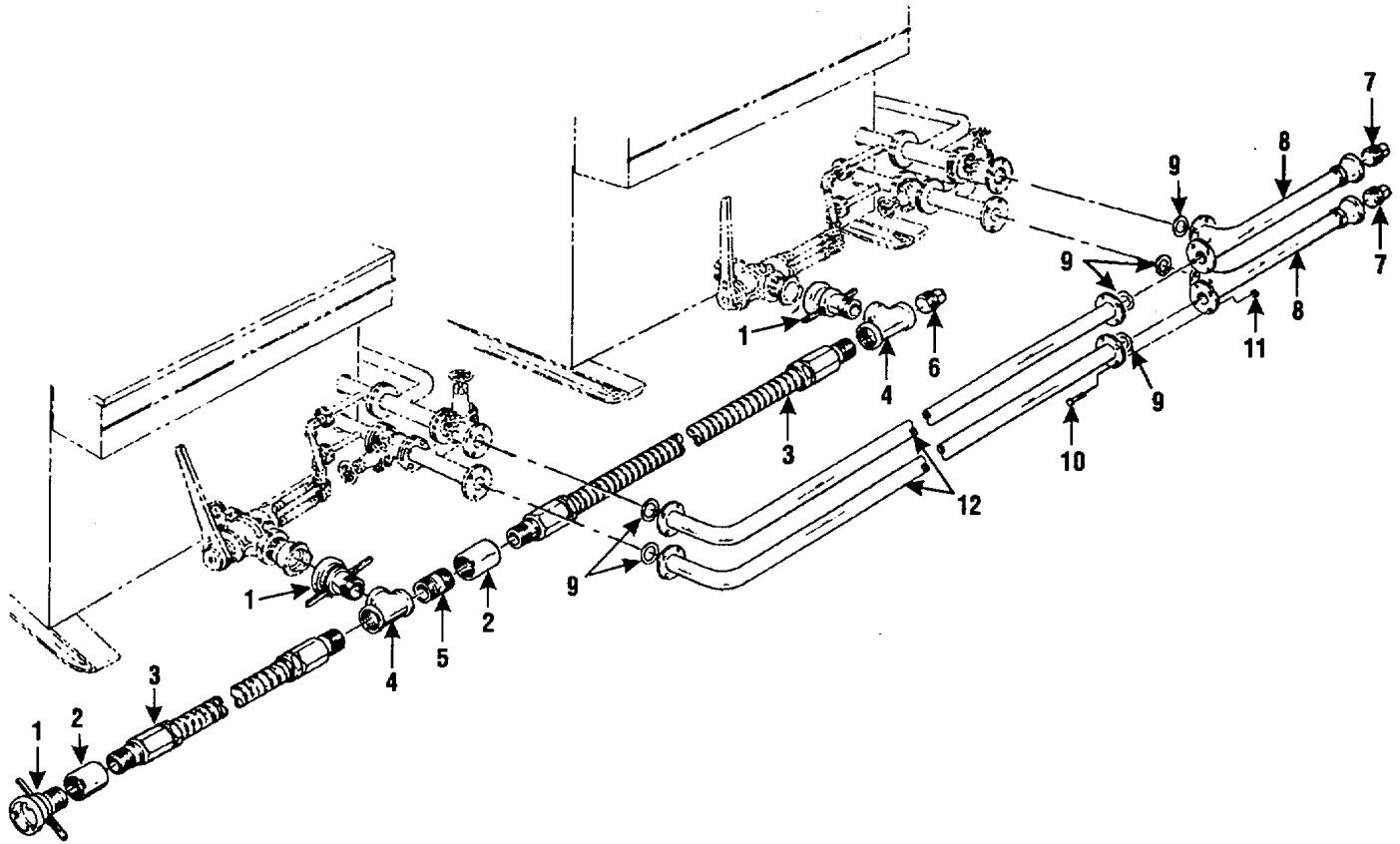

- | | | | |
|------------------|------------|----------------------|-------------------------------------|
| 1. Connector (3) | 4. Tee (2) | 7. Plug (2) | 10. Capscrew, 5/8NC x
2 1/2 (24) |
| 2. Coupling (2) | 5. Nipple | 8. Pipe Assembly (2) | 11. Nut, 5/8NC (24) |
| 3. Hose (2) | 6. Plug | 9. Gasket (6) | 12. Pipe Assembly (2) |

Figure 2-6. Hot Oil and Asphalt Piping for Multiple Unit Installation.

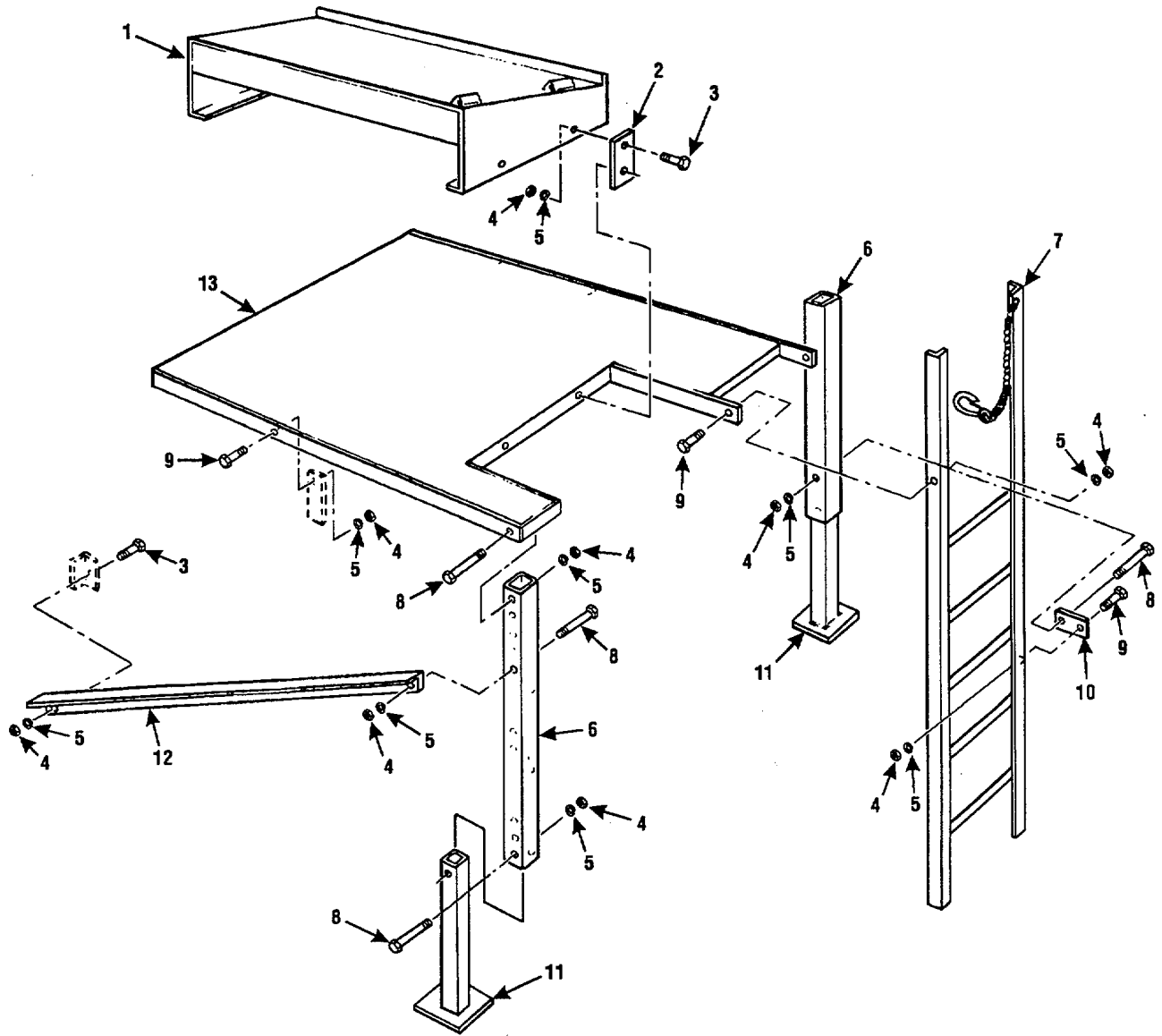

- | | | |
|------------------------------|-----------------------------|------------------------|
| 1. Load Ramp | 6. Leg (2) | 11. Leg Extension (2) |
| 2. Ramp Bracket (2) | 7. Ladder | 12. Platform Brace (2) |
| 3. Capscrew, 3/8NC x 1 (6) | 8. Capscrew, 3/8NC x 3 (7) | 13. Load Platform |
| 4. Nut, 3/8NC (18) | 9. Capscrew, 3/8NC x 1½ (5) | |
| 5. Lockwasher, 3/8 I.D. (18) | 10. Ladder Brace | |

Figure 2-7. Load Platform, Ladder and Associated Parts.

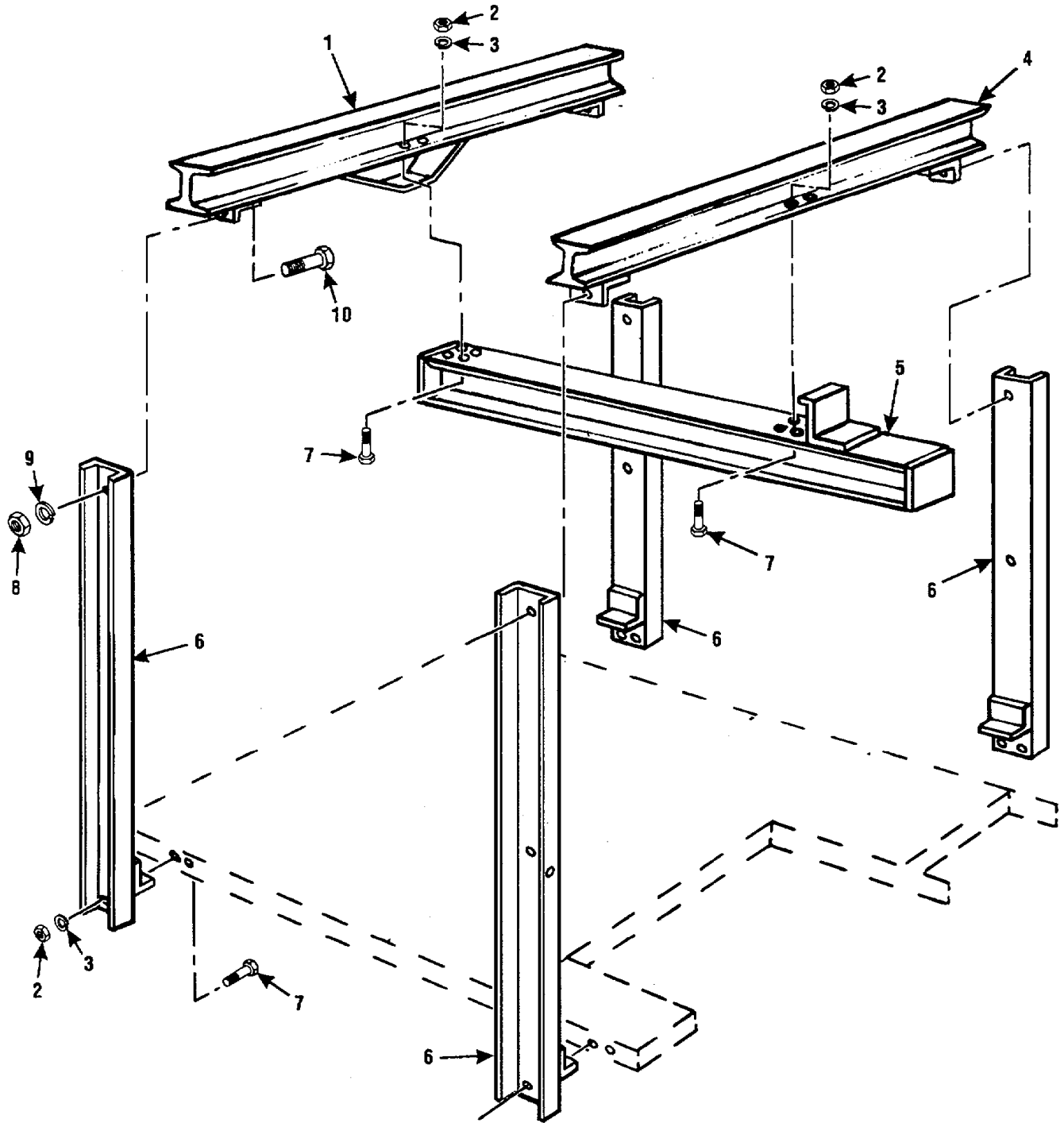

- 1. Rear Cross Beam
- 2. Nut, 3/8NC (16)
- 3. Lockwasher, 3/8 I.D. (16)
- 4. Front Cross Beam

- 5. Trolley Rail
- 6. Up-Right Support (4)
- 7. Capscrew, 3/8NC x 1 1/2 (7)
- 8. Nut, 5/8NC (4)

- 9. Lockwasher, 5/8NC I.D. (4)
- 10. Capscrew, 5/8NC x 1 1/2 (4)

Figure 2-8. Load Platform Upper Structure.

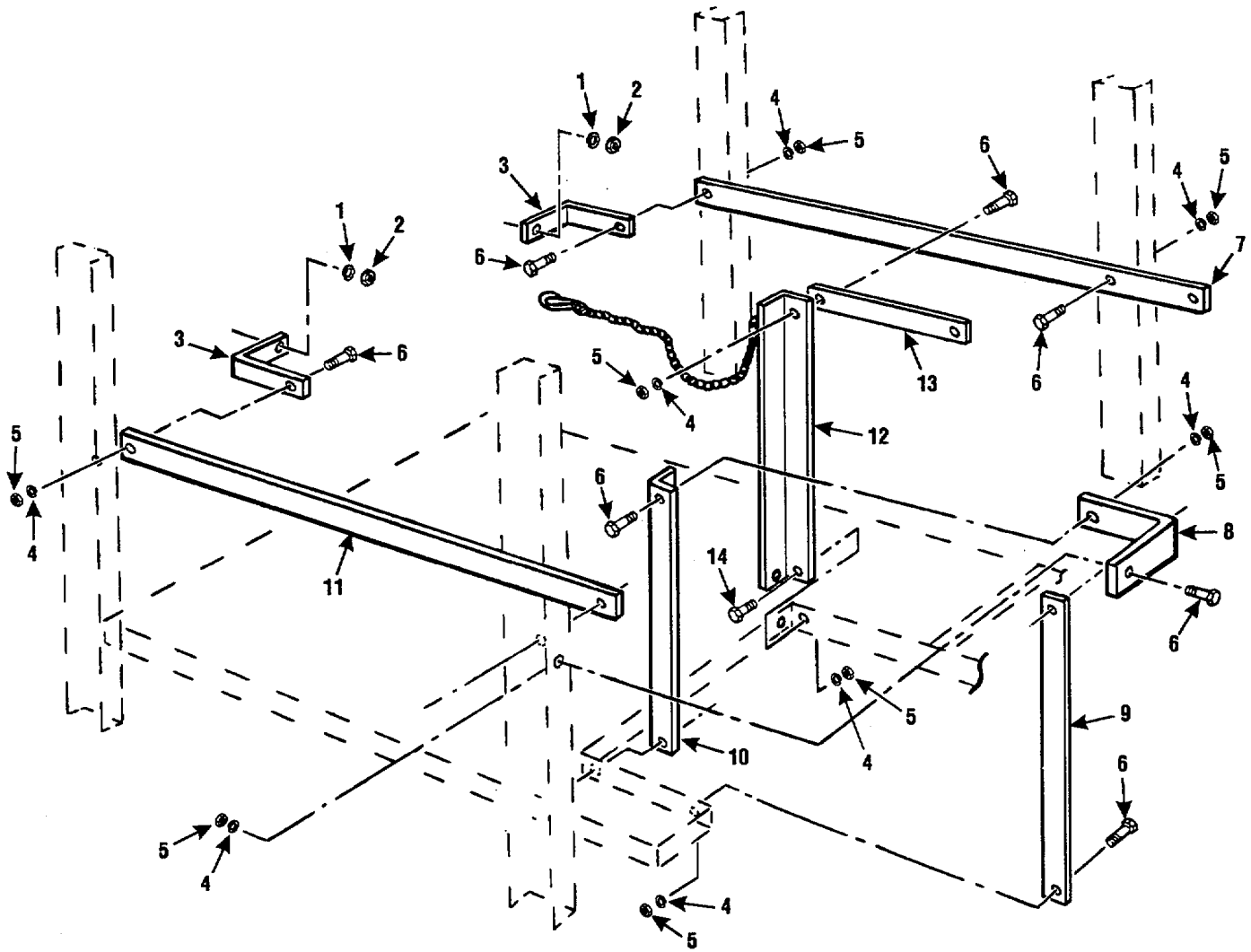

- | | | | |
|--------------------------------|-----------------------------------|-------------------------|--------------------------------|
| 1. Lockwasher, 1/2 I.D.
(2) | (13) | 8. Front Corner Railing | 13. Ladder Railing |
| 2. Nut, 1/2NC (2) | 5. Nut, 3/8NC (13) | 9. Front Rail Support | 14. Capscrew, 3/8NC x
1 (4) |
| 3. Rear Rail Corner (2) | 6. Capscrew, 3/8NC x 1
1/2 (9) | 10. Right Rail Support | |
| 4. Lockwasher, 3/8 I.D. | 7. Railing, Left Side | 11. Railing Right Side | |
| | | 12. Left Rail Support | |

Figure 2-9. Guard Rails.

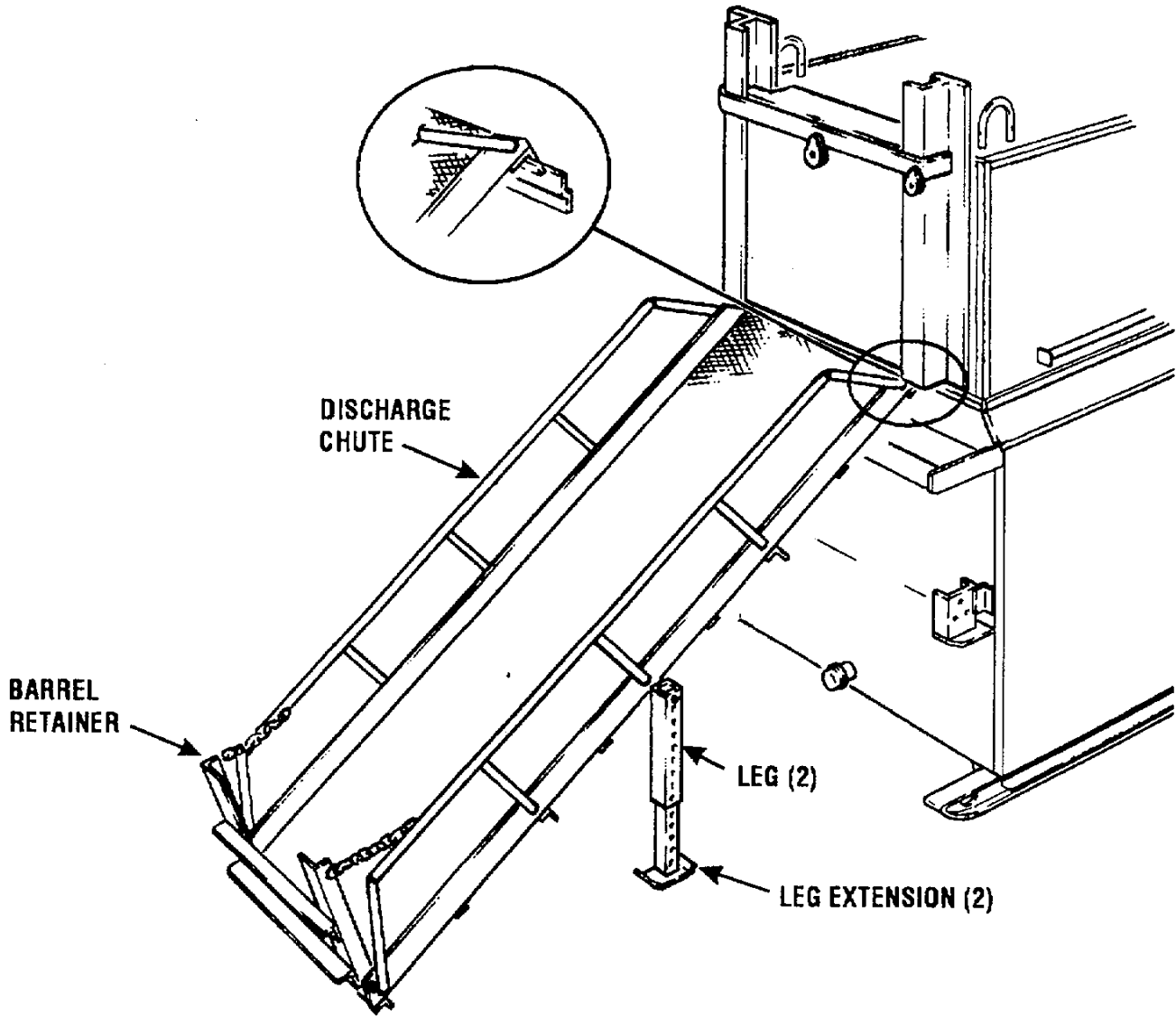

Figure 2-10. Discharge Chute Installation.

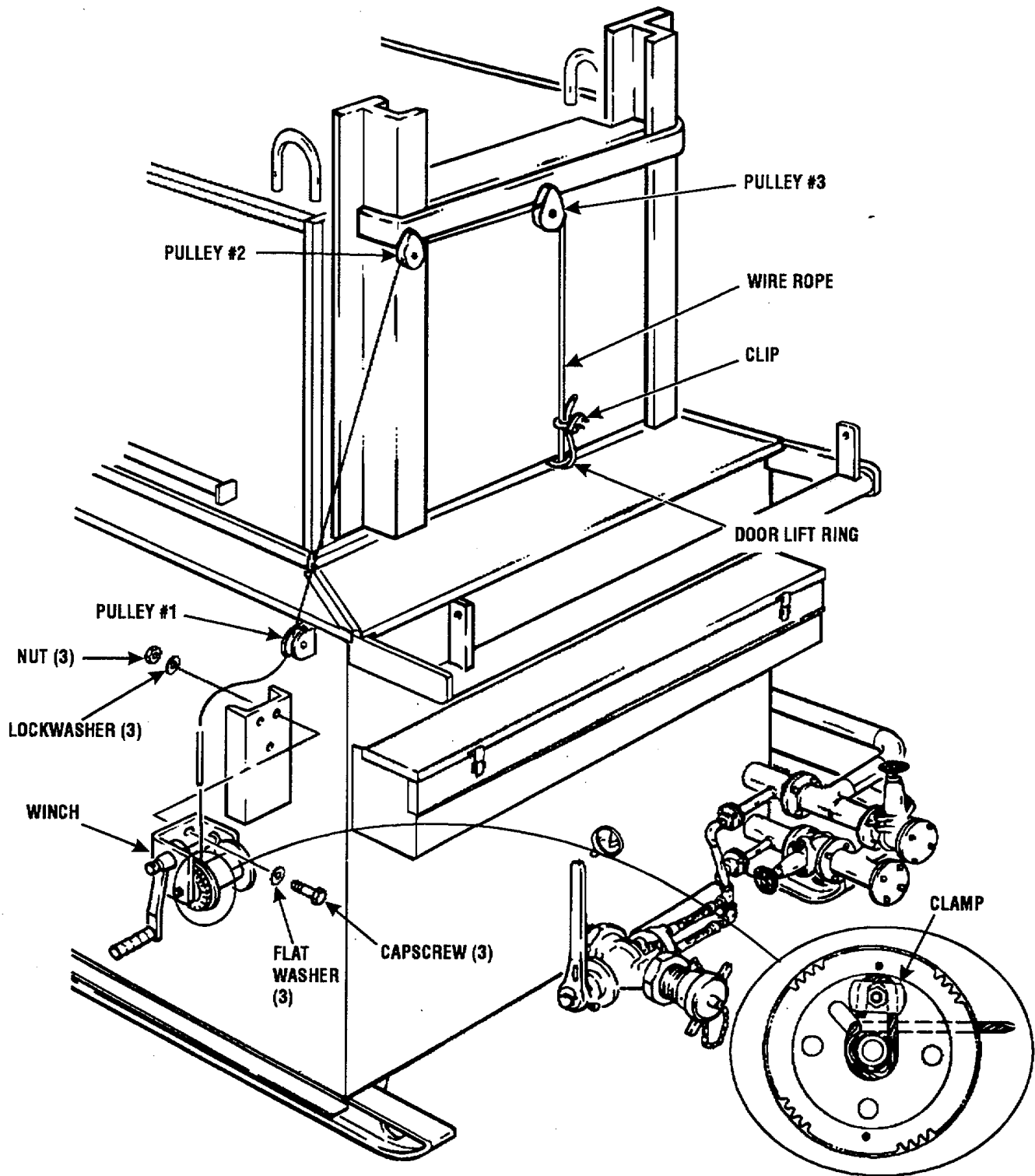
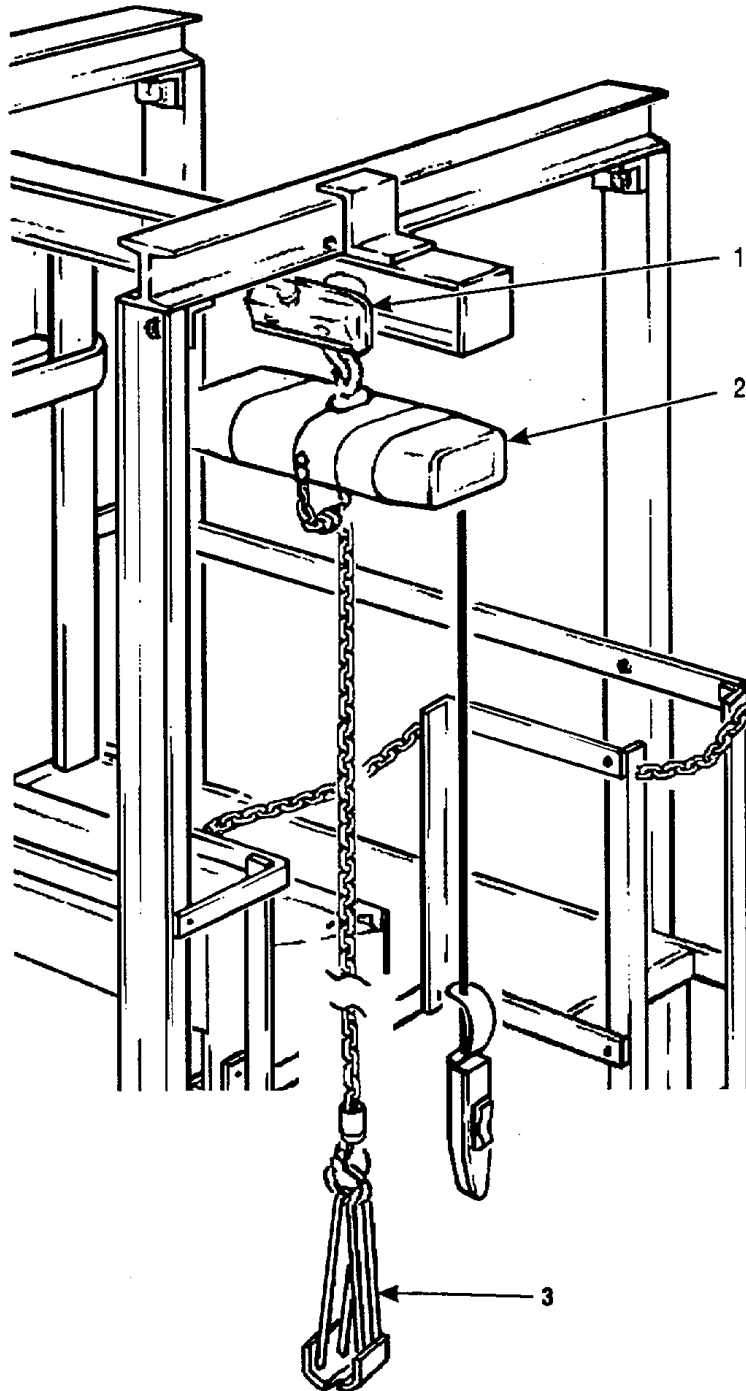

Figure 2-11. Winch Installation.



- 1. Trolley
- 2. Hoist
- 3. Drum Sling

Figure 2-12. Hoist and Trolley Installation.

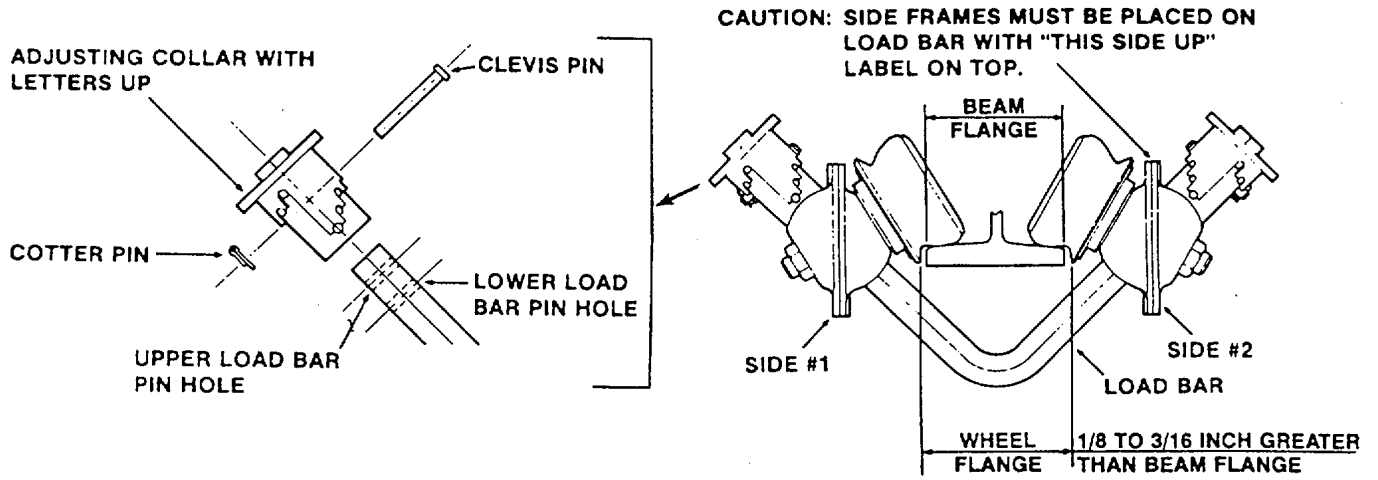

Figure 2-13. Trolley Installation and Adjustment.

Section III. - OPERATING INSTRUCTIONS

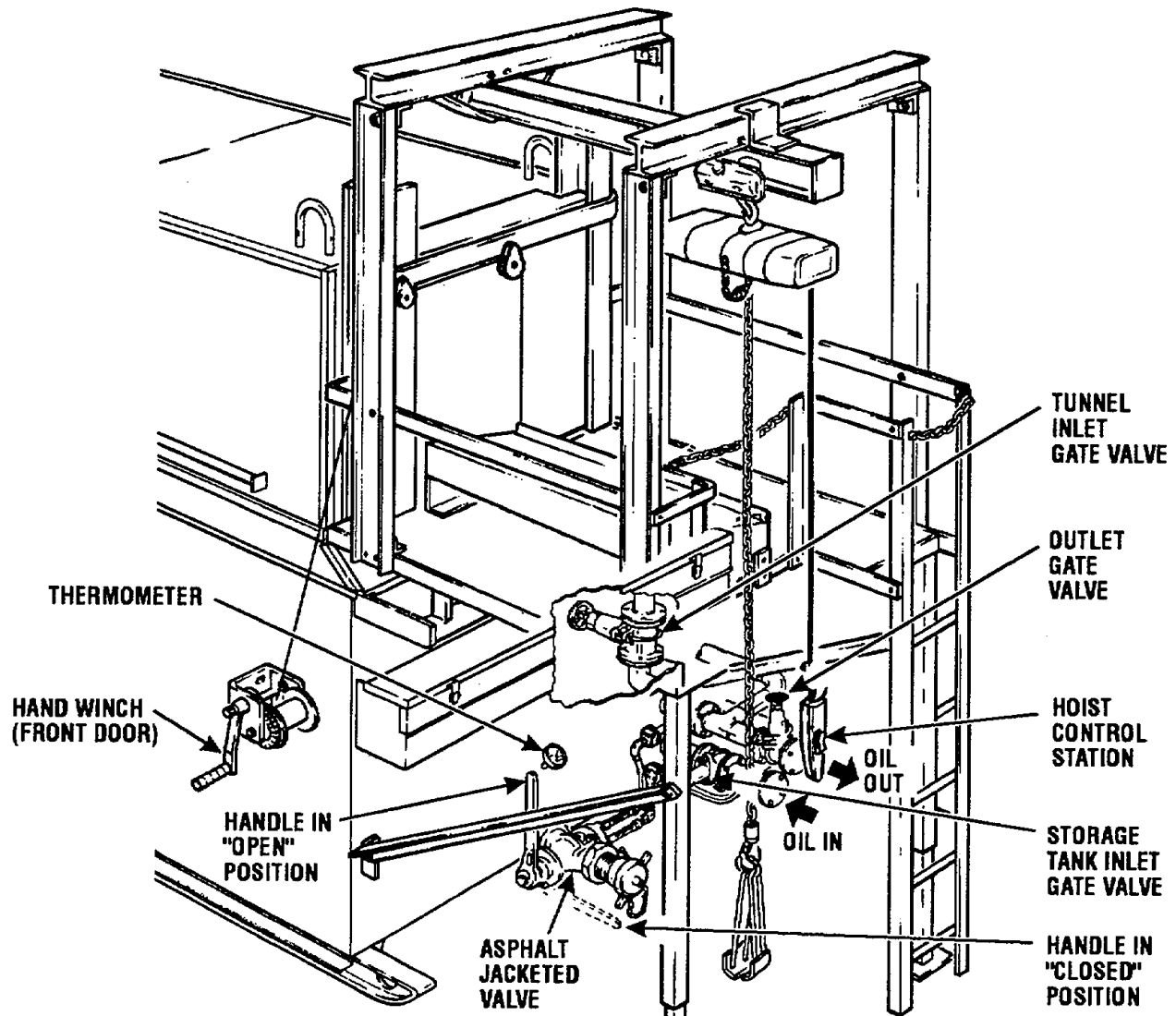

Figure 3-1. Controls and Instruments.

3-1. Controls and Instruments.

a. *General.* Before beginning operation of the asphalt melter unit, operators should become thoroughly familiar with the location and function of all controls and instruments. The following paragraphs describe each control and instrument unique to the asphalt melter. Consult operator instructions supplied with heat source unit and asphalt distributor pump for identification of controls on those units.

b. *Thermometer.* The asphalt material temperature gauge (Figure 3-1) is a direct, gauge reading, bi-metal thermometer for monitoring the temperature of the melted asphalt material in the storage tank. For most efficient transfer of asphalt material, temperature should be maintained at approximately 235°F. for 85-100 penetration asphalt cement.

c. *Tunnel Inlet Gate Valve.* The tunnel inlet gate valve (Figure 3-1), located at the right side of the melter, is an all iron, rising stem gate valve, with a forged steel

disc. This valve is used to regulate the flow of heat transfer oil to the heat coils of the de-drumming tunnel. During dedrumming operations, this valve is normally in the full open position. When de-drumming has been completed, this valve is closed, directing all heat transfer oil to the heat coils in the bottom of the storage tank.

d. *Storage Tank Inlet Gate Valve.* The storage tank inlet gate valve (Figure 3-1), located on the lower piping connection to the storage tank, is identical in construction to the tunnel inlet gate valve. This valve regulates the flow of heat transfer oil to the heating coils in the storage tank. During de-drumming operations, this valve must be used in conjunction with the tunnel inlet gate valve to divide the flow of heat transfer oil between

the tunnel and the storage tank. When de-drumming this valve must be partially closed to divert most of the heat transfer oil flow to the tunnel coils, but must not be completely closed. Melted asphalt cement that is allowed to drop onto cool or cold coils in the storage tank will quickly solidify, resulting in the loss of time and additional consumption of energy to remelt the asphalt. After de-drumming operations are completed, this valve may be fully opened.

e. *Outlet Gate Valve.* The outlet gate valve (Figure 3-1), located on the upper piping connection to the storage tank, is identical in construction to the tunnel inlet gate valve. This valve is used to throttle the flow of heat transfer oil through the melter, providing control of the temperature. Opening this valve fully will tend to raise the temperature; while partial closing of this valve will restrict the flow and tend to lower the temperature.

f. *Asphalt Jacketed Valve.* The asphalt jacketed valve (Figure 3-1) is a plug type, rotary valve, with cored jacket for the flow of heat transfer oil to heat the valve assembly. The valve stem and collar provide positive stops in the full open and full closed position. For valve installation shown, the valve is fully open when lever is straight up and fully closed when lever is horizontal, pointing away from the storage tank.

WARNING

WHEN OPENING THE DOORS, ALWAYS CHECK THAT THE RATCHET LOCK IS SET AND HOLDING BEFORE RELEASING THE WINCH HANDLE. INJURY TO PERSONNEL MAY RESULT IF DOOR SHOULD DROP UNEXPECTEDLY.

g. *Hand Winch.* The two hand winches (front winch, Figure 3-1) are used to open and close the tunnel doors for loading and unloading barrels. Crank the handle clockwise to raise (open) the door. The door will be held open when winch handle is released. To lower (close) the door, turn the winch handle in a counter-clockwise direction, until door is completely closed. The winch for the rear discharge door is located on the rear of the storage tank near the right side of the melter.

h. *Hoist Control Station.* The hoist control station (Figure 3-1) is a two-position, momentary contact, rocker switch with center "off/braked" position. Depressing the rocker switch on the upper side will raise the load, while depressing the lower side will lower the load. When changing direction of travel for the load, release the rocker switch completely to stop travel prior to depressing rocker for opposite direction.

3-2. Initial Start-Up.

WARNING

OPERATOR MUST WEAR PERSONAL PROTECTIVE EQUIPMENT WHILE WORKING WITH HOT ASPHALT. FULL FACE SHIELD, LEATHER OR RUBBER SAFETY SHOES, HEAVY INSULATED GLOVES, AND PROTECTIVE CLOTHING SUCH AS COVERALLS COVERING ALL EXPOSED SKIN OR ARMS AND LEGS.

CAUTION

Do not operate the asphalt melter in the rain. Operation of melter during rain may cause the asphalt to boil and catch fire. After a rain or during humid conditions, open the tunnel doors and dry the unit before operating. Keep the heat transfer piping system full to minimize condensation.

a. Inspect installation of melter unit and all piping for proper connections.

b. Refer to operating instructions of heat source plant, and start heater. Adjust heater as required to insure delivery of heat requirements of melter.

c. Close the asphalt jacketed valve.

d. Open all three gate valves on heat transfer oil piping. Tunnel inlet and outlet gate valves should be opened fully, with the storage tank inlet valve opened only half way.

e. Open the tunnel front door and using the electric hoist, load six asphalt drums, open end on low side, on load ramp of the tunnel. Push each drum as loaded to rear of tunnel with the barrel ram.

NOTE

Loading of drums must be done quickly. Asphalt may start to come out of the open drums and adhere to heat coils, preventing their being moved farther into the tunnel. If this happens, close the door and allow asphalt to melt completely before proceeding to load melter.

f. When all drums are loaded, close the front door of tunnel and allow the asphalt to melt and drain into the storage tank.

g. When all drums are empty, open doors at both the front and rear of the tunnel. Load new full asphalt drums in same manner as loading of initial load. Empty drums will be pushed out the open rear door as full drums are loaded into the front.

3-3. Operating Instructions.

a. Perform initial start-up as instructed in paragraph 3-2.

b. When initial charge of drums is empty, open doors at both the front and rear of the tunnel. Load new asphalt drums in same manner as loading of initial load. Empty drums will be pushed out the rear door as full drums are loaded into the front.

CAUTION

Do not overload storage tank. The tank will hold 3000 U.S. gallons. Keep records of amount loaded and pumped out, to insure that capacity is not exceeded.

c. Continue loading the de-drumming tunnel as required to provide amount of asphalt required for job application.

CAUTION

Temperature of asphalt must not exceed 3500 F, while operating. Reduce temperature to 300° F, during standby operation. Prolonged operation at temperatures above 350° F, may result in asphalt igniting and burning, which may damage the melter. Flash point for asphalt is 425-450° F.

d. Periodically monitor the thermometer, on front of tank for proper operating temperature range, 235° ±15° F. for asphalt cement rated at 85-100 penetration.

Temperature of asphalt cement in storage tank may be lowered by adjustment of heat transfer oil gate valves to restrict flow of hot oil to coils of storage tank. Do not restrict oil flow to tunnel during de-drumming operations, maximum heat is desired to shorten melt-down of asphalt cement.

e. Transfer melted asphalt cement from storage tank by starting supplied material pump and opening the asphalt jacketed valve (Figure 3-1). Meter the flow of asphalt pumped from the tank, so a record can be maintained of the amount of material in the tank at all times.

f. When required amount of asphalt has been melted, close the tunnel inlet gate valve (Figure 3-1). Push empty drums from the tunnel with barrel ram. Adjust storage tank inlet and outlet gate valves (Figure 3-1), as necessary to maintain proper temperature in the tank.

3-4. Shutdown Instructions.

a. All melted asphalt cement must be pumped from the storage tank. Visually check storage tank by removing front rain shield.

b. When satisfied that all material has been pumped from storage tank, close the asphalt jacketed valve (Figure 3-1).

NOTE

Not all material can be removed by pumping, approximately 1-1/2 to 2 inches of material will remain in the storage tank c. Disconnect asphalt flexible hose piping and drain all material.

d. Shutdown hot oil heater (Refer to heater instructions.) e. Close all gate valves (Figure 3-1).

Section IV. - MAINTENANCE INSTRUCTIONS

4-1. Cleaning Instructions.

a. Periodic cleaning out, by Direct Support Maintenance personnel, of residue and sludge provides for a more efficient operation of the Asphalt Melter; and when moving the melter to a new worksite, reduces the overall weight.

b. Effort required to clean out the asphalt melter can be held to a minimum by draining all asphalt material, when hot, before unit is shut down. Remove the rear drain cap (10, Figure 4-1) to drain the storage tank. Dispose of drained residue in accordance with local safety regulations.

WARNING

ALLOW UNIT TO COOL TO AMBIENT TEMPERATURE BEFORE STARTING CLEANING OPERATIONS OR DISMANTLING OF UNIT. UNIT OPERATES AT 235°F, SEVERE BURNS MAY RESULT IF CONTACT IS MADE WITH UNIT.

c. Before beginning clean out procedures, the unit must be partially dismantled to gain access to the storage tank (see paragraph 4-3). Do not disassemble the melter farther than needed. To properly clean storage tank the storage tank heating coil (4, Figure 4-1) must be removed.

WARNING

- **TUNNEL MUST BE REMOVED A MINIMUM OF 24 HOURS PRIOR TO ENTRY INTO STORAGE TANK. CHEMICAL CONTAMINANTS MAY BE PRESENT AND MAY CAUSE SICKNESS OR IRRITATION.**
- **CHECK WITH LOCAL SAFETY OFFICE FOR CONFINED SPACE ENTRY REQUIREMENTS.**
- **DRY CLEANING SOLVENT (P-D680) IS TOXIC AND FLAMMABLE. WEAR PERSONAL PROTECTIVE EQUIPMENT, TO INCLUDE NITRILE RUBBER GLOVES/ APRONS AND A FULL FACE SHIELD; USE ONLY IN A WELL-VENTILATED AREA; AVOID CONTACT WITH SKIN, EYES, AND CLOTHES AND DO NOT BREATHE VAPORS. KEEP AWAY FROM**

HEAT OR FLAME. NEVER SMOKE WHEN USING SOLVENT. (FLASH POINT FOR TYPE III SOLVENT IS 2000F.) FAILURE TO DO SO MAY RESULT IN INJURY OR DEATH TO PERSONNEL. REFER TO WARNINGS PAGE B FOR MORE INFORMATION.

d. Clean walls and floor of storage tank and tunnel support beams by scraping.

e. The asphalt flexible hose and disconnect couplings (Figure 2-6) may be cleaned by soaking in a trough filled with approved cleaning solvent.

f. Allow the unit to thoroughly air dry before attempting to reassemble the melter.

4-2. Lubrication Instructions.

Lubricate the asphalt melter monthly as follows:

- a. Apply a drop of SAE 10 grade oil (MIL-L-2104E) to the bushings of the door winches.
- b. Use a clean rag to apply oil (Lubriplate, Bar and Chain Oil 10-R, or equivalent) to the load chain.

4-3. Maintenance Instructions.

a. The asphalt melter, is designed and constructed, to be virtually maintenance free. Most all damage or deterioration of the melter will be the direct result of careless operation or handling during installation and/or disassembly.

WARNING

- **ALLOW UNIT TO COOL TO AMBIENT TEMPERATURE BEFORE PERFORMING ANY MAINTENANCE ON THE UNIT. UNIT OPERATES AT 235°F, SEVERE BURNS MAY RESULT IF CONTACT IS MADE WITH UNIT.**
- **TUNNEL MUST BE REMOVED A MINIMUM OF 24 HOURS PRIOR TO ENTRY OF STORAGE TANK. CHEMICAL CONTAMINANTS MAY BE PRESENT AND MAY CAUSE SICKNESS OR IRRITATION.**
- **CHECK WITH LOCAL SAFETY OFFICE FOR CONFINED SPACE ENTRY REQUIREMENTS.**

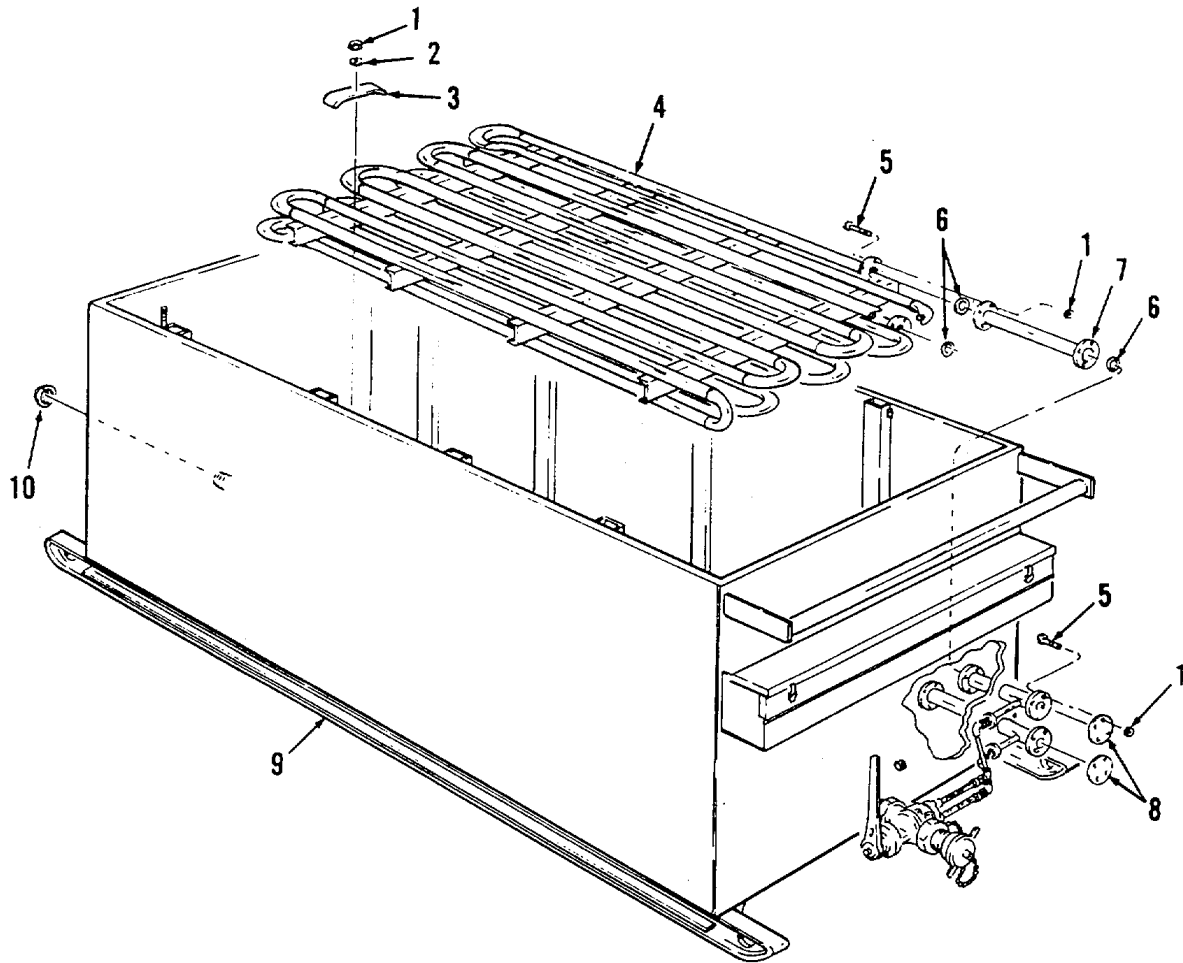

- | | | | |
|---------------------|------------------|------------------|---------------|
| 1. Nut (4) | 4. Heater Coil | 7. Pipe Assembly | 10. Pipe Cape |
| 2. Washer (4) | 5. Capscrew (20) | 8. Cover (2) | |
| 3. Holddown Bar (4) | 6. Gasket (3) | 9. Storage Tank | |

Figure 4-1. Storage Tank and Heater Coil.

b. During operation, periodically inspect all hot oil piping connections for signs of leakage. Asphalt cement must be drained from the tank to the three piping connections inside storage tank. Tighten all leaking connections or replace ring gasket(s) as required.

c. The three, 2-inch gate valves (7, Figure 2-3) used in the hot oil piping, are each equipped with stem packings. Tighten packing nut, if signs of oil leakage is evident around the stem.

d. Should there be signs of oil contaminating the asphalt cement, first check the three hot oil piping connections inside the storage tank. If no leakage is evident, inspect for broken weld on coil piping inside the storage tank or tunnel. Tighten flange bolts or weld

piping as necessary.

e. For disassembly of melter for repair or parts replacement refer to figures 2-2 through 2-12 for parts relationship and remove and replace defective component.

f. Replace storage tank heating coil (4, Figure 4-1) as follows:

- (1) Drain storage tank (paragraph 4-1).
- (2) Remove four holddown bars (3, Figure 4-1).
- (3) Remove eight bolts and nuts which secure coil connector pipe (7), and remove the connector pipe and two ring gaskets (6).

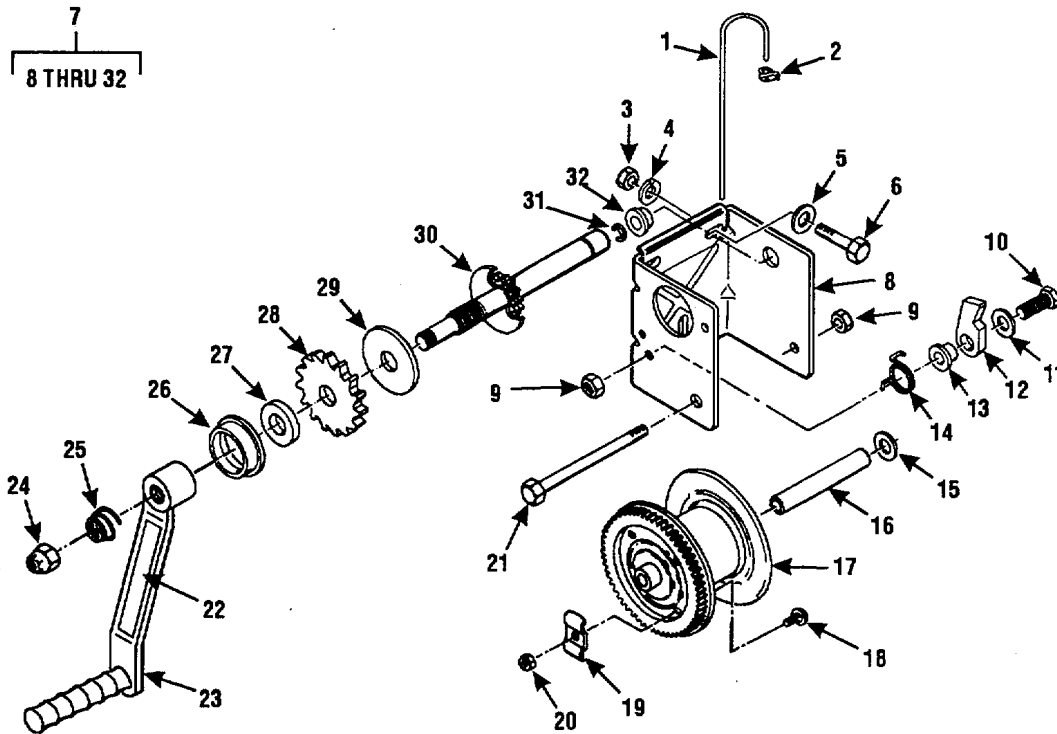

- | | | | |
|-------------------|----------------|-------------|--------------------|
| 1. Wire Rope | 9. Locknut (2) | 17. Reel | 25. Spring |
| 2. Clip | 10. bolt | 18. Bolt | 26. Bushing |
| 3. Nut (3) | 11. Washer | 19. Clamp | 27. Washer |
| 4. Lockwasher (3) | 12. Pawl | 20. Nut | 28. Ratchet Wheel |
| 5. Washer (3) | 13. Spacer | 21. Shaft | 29. Pressure Plate |
| 6. Capscrew (3) | 14. Spring | 22. Decal | 30. Drive Shaft |
| 7. Winch Assembly | 15. Spring | 23. Handle | 31. Retaining Ring |
| 8. Base | 16. Spacer | 24. Locknut | 32. Bushing |

Figure 4-2. Hand Winch Assembly.

- (4) Remove four bolts and nuts from lower flanged coil connection, and lift coil (4) from the storage tank. Remove ring gasket (6) from face of flanges.
- (5) Using new ring gaskets (6), install the storage tank heating coil (4) in reverse of instructions of paragraphs (1) through (4) above.

g. Refer to figures 2-2 through 2-12 for identification and location of components, removing, repairing or replacing as required. See paragraph 4-4 for instructions on repair of the hand winch (Figure 2-11), and paragraph 4-5 for repair instructions on the electric

hoist (2, Figure 2-12).

4-4. Winch Repair Instructions.

a. Removal.

- (1) Loosen nut (20, Figure 4-2), releasing clamp (19) from wire rope (1). Unreeve wire rope from the reel (17).
- (2) Remove three nuts (3), lockwashers (4), flat washers (5) and capscrews (6) that secure the hand winch assembly (7) to bracket on melter storage tank.

b. Disassembly.

- (1) Remove locknut (9) and shaft (21) that secures the reel (17). Remove reel, thrust washer (15), and spacer (16).
- (2) If necessary, remove the hex nut (20), clamp (19) and carriage bolt (18).
- (3) Note how spring (14) engages the hole in base (8), and hooks onto the ratchet pawl (12). Remove locknut (9), bolt (10), washer (11), pawl (12), spring (14), and bushing (13).
- (4) Secure drive shaft (30) and remove locknut (24), spring (25) and thread handle (22) counter-clockwise off the shaft.
- (5) Remove retaining ring (31) and slide drive shaft (30) through the bushing (32) to allow removal of washer (27), ratchet wheel (28), and pressure plate (29).
- (6) Push flanged bushing (32) from hole in base (8) and tip drive shaft (30) to remove from base. Remove flanged bushing (32) from drive shaft.
- (7) Remove flanged bushing (26) from large hole in base (8).

c. Cleaning.

WARNING

DRY CLEANING SOLVENT (P-D-680) IS TOXIC AND FLAMMABLE. WEAR PERSONAL PROTECTIVE EQUIPMENT, TO INCLUDE NITRILE RUBBER GLOVES/APRONS AND FULL FACE SHIELD; USE ONLY IN A WELL-VENTILATED AREA; AVOID CONTACT WITH SKIN, EYES, AND CLOTHES AND DO NOT BREATHE VAPORS. KEEP AWAY FROM HEAT OR FLAME. NEVER SMOKE WHEN USING SOLVENT. (FLASH POINT FOR TYPE III SOLVENT IS 2000F.) FAILURE TO DO SO MAY RESULT IN INJURY OR DEATH TO PERSONNEL. REFER TO WARNINGS PAGE B FOR MORE INFORMATION.

- (1) Clean all parts except pressure plate (29)

in an approved cleaning solvent and dry thoroughly.

d. Inspection.

- (1) Inspect bushings (13, 26, and 32) for wear or other damage.
- (2) Inspect faces of pressure plate (29) and mating faces of ratchet wheel (28) and drive shaft (30) for scoring or contamination with lubricant.
- (3) Inspect threads on all threaded parts for stripped threads or other damage.
- (4) Inspect ratchet wheel (28), drive shaft (30) and reel (17) for deformed or missing teeth.
- (5) Inspect tip of pawl (12) for wear that would prevent it from catching securely on ratchet wheel (28).
- (6) Replace any part found defective in any way.

e. Assembly.

CAUTION

Do not allow grease or oil to get on faces of pressure plate (29) or its mating faces of ratchet wheel (28) and drive shaft (30). Brake will fail to hold load if these surfaces are contaminated with lubricant.

- (1) Apply small amount of grease (MIL-G10924) to shaft (21), spacer (16) and to teeth of reel (17).
- (2) Apply a few drops of SAE 10 grade oil (MILL-2104E) to flanged bushing (26), and install in the large opening in side of base (8). The flange of bushing must be on the inside of the base.
- (3) Apply a few drops of SAE 10 grade oil (MILL-2104E) to flanged bushing (32), and install on drive shaft (30) with flanged side leading.
- (4) Insert end of drive shaft (30) through hole in base (8) opposite the large opening. Insert the shaft as far as it will go.
- (5) Install pressure plate over end of drive shaft (30) and seat against pressure face of drive shaft.

- (6) Install ratchet wheel (28) over end of drive shaft (30) with teeth pointing in a counterclockwise direction. Seat the ratchet wheel by turning to engage locking flat.
- (7) Install washer (27) onto drive shaft (30) and guide end of shaft through bushing (26), seating washer in recess of bushing.
- (8) Secure drive shaft by installing retaining ring (31) into groove of drive shaft.
- (9) Apply a few drops of SAE 10 grade oil (MIL L-2104E) to flanged bushing (13) and install in bore of pawl (12) as shown.
- (10) Install washer (11), pawl (12) with bushing (13) and spring (14) on bolt (10). Install assembly into base (8), engaging ends of spring (14) as noted during disassembly, to apply torque to pawl to hold the pawl tip against the ratchet wheel (28). Secure bolt with locknut (9), tightening sufficiently to secure parts without restricting movement of pawl.
- (11) If removed, install bolt (18) through wall of reel (17) and secure clamp (19) with nut (20).
- (12) Install reel (17), spacer (16), and thrust washer (15) into base (8) and secure with shaft (21) and locknut (9).
- (13) Apply a few drops of SAE 10 grade oil (MILL-2104E) to threads of handle (25) and install handle onto end of drive shaft (30), turning clockwise until a clicking noise is heard. Install spring (25) as shown and secure with locknut (24). Turn locknut onto end of shaft until end of locknut is flush with end of shaft.
- (14) If necessary place new decal (22) on handle (23).

a. Installation.

- (1) Install the hand winch as instructed in paragraph 2-4l.

4-5. Electric Hoist Repair Instructions.

a. Removal.

- (1) Disconnect the power cord from electrical power source.
- (2) Remove drum sling (3, Figure 2-12) from lower hook of hoist (2).

- (3) Unhook upper hook of hoist from trolley and remove hoist from melter.
- b. Load Chain Replacement (Figure 4-4).

- (1) Remove capscrew (14), lockwasher (13), and flat washer (12) to release end of loose end chain (15) from motor housing (56).
- (2) Mount loose end block (16) in vice and with suitable drift, drive pin (18) from loose end block (16), and detach load chain (55) and stop block (19).

WARNING

EYE PROTECTION MUST BE WORN WHEN GRINDING OR CUTTING CHAIN. FLYING PARTICLES CAN BE PRODUCED, WHICH CAN CAUSE INJURY TO PERSONNEL.

- (3) Using a 7" minimum diameter of 1/8" thick abrasive wheel that will clear adjacent links, cut a portion out of the second to last link (flat link) on loose end of load chain (55). Center a 3/8" long cutout on the weld of the link, to form a coupling link. Remove and discard the last link.
- (4) Attach new load chain (55) to the old chain with the coupling link just created. Ensure that the first link of the new chain is an upstanding link with the weld facing away from the liftwheel (21).
- (5) Attach power cord to a 110 Volt power source and operate the hoist in the DOWN direction until approximately 2-1/2 feet of new chain remains on the loose end side. Disconnect power cord.
- (6) The last link on the loose end side of the new load chain must be an up-standing link. If last link is not an up-standing link, cut it off using cutting procedure as described in step 3, above.
- (7) Slide stop block (19) onto new load chain's last link and secure that link to loose end block (16) with a new pin (18).
- (8) Attach loose end chain to motor housing (56) with flat washer (12), lockwasher (13), and capscrew (14).
- (9) Position the lower hook body (46) in a vice with the small end of tapered groove pin

(53) facing up. Using a 3/8 inch drift, drive the pin loose from the body (46) and the block (54). Remove old load chain (55) from block (54).

- (10) Rotate the lower hook body (46) until the larger pin hole is facing up. Slide last link of new load chain in slot of block (54) and position block into lower hook body, ensuring that opening of the pin hole is aligned with the pin hole in hook body. Install pin (53), small end first, and seat pin with hammer until flush with surface of hook body.

c. Disassembly - Brake End (Figure 4-3).

- (1) Remove two screws (13) and lockwashers (14) and remove cover (11).
- (2) Tag and disconnect leads from power cable (23), control cable (20), and contactor (36).

NOTE

It is not necessary to disconnect all jumper leads from contactor (36) unless replacement of leads or contactor is required.

- (3) Remove screw (16), lockwasher (17), washer (18), control cable (20), and power cable ground lead from anchor boss in frame assembly.
- (4) Remove screw (41) and contactor assembly (36) from gear housing.
- (5) If necessary, remove screws (35) and separate bracket (38) from contactor assembly (36).
- (6) Remove two nuts (10), and carefully lift off the brake field (8) with coil (7), springs (6), brake armature (5), friction plate (2), brake disc (3), friction plate (4), brake disc (3), friction plate (2) and brake plate (1).
- (7) If necessary, remove coil (7) and strap (9) from brake field (8).

NOTE

If rotor armature (5) or field (8) require replacement, both parts must be replaced.

- (8) Remove retaining ring (40) and brake hub (39).

d. Disassembly - Gear and Hook Section (Figure 4-4).

- (1) Remove hook assembly (42) and load chain (55) as described in paragraph b. above, and remove chain from hoist.
- (2) Drive pin (52) from castle nut (43), and remove the nut, thrust bearing (44), washer (45) and body (46) from the hook (47).
- (3) If necessary, remove nut (51), screw (49), latch (48), and latch spring (50) from hook (47).
- (4) Remove the hoist brake section, paragraph c. above.
- (5) Remove three machine screws (31) and carefully separate frame assembly (25) from gear housing (40). Remove and discard gasket (24).
- (6) Lift out shaft and pinion assembly (35).
- (7) Lift out intermediate pinion (39) with protector (38). Pull bearing (36) from intermediate pinion (39). Remove retaining ring (37) and protector (38) from the intermediate pinion (39). Do not disassemble the protector (38), the unit is considered non-repairable.
- (8) Remove retaining ring (34) and gear (33).
- (9) Remove other bearing (36) from bore in frame assembly (25).
- (10) If necessary for replacement of frame assembly (25), remove screw (30), lockwasher (29), washer (28) and plugs (27).
- (11) Loosen screws (7) and remove four screws (32) and carefully separate the gear housing (40) and the motor housing (56).
- (12) Remove nut (20) from slot in motor housing (56). Lift out upper hook assembly (2) with adapter (8).
- (13) Remove bearing (41) from gear housing (40).
- (14) Remove bearing (23), chain guides (22), and lift wheel (21).
- (15) If necessary, remove two screws (7) and nuts (9) from the upper hook assembly.

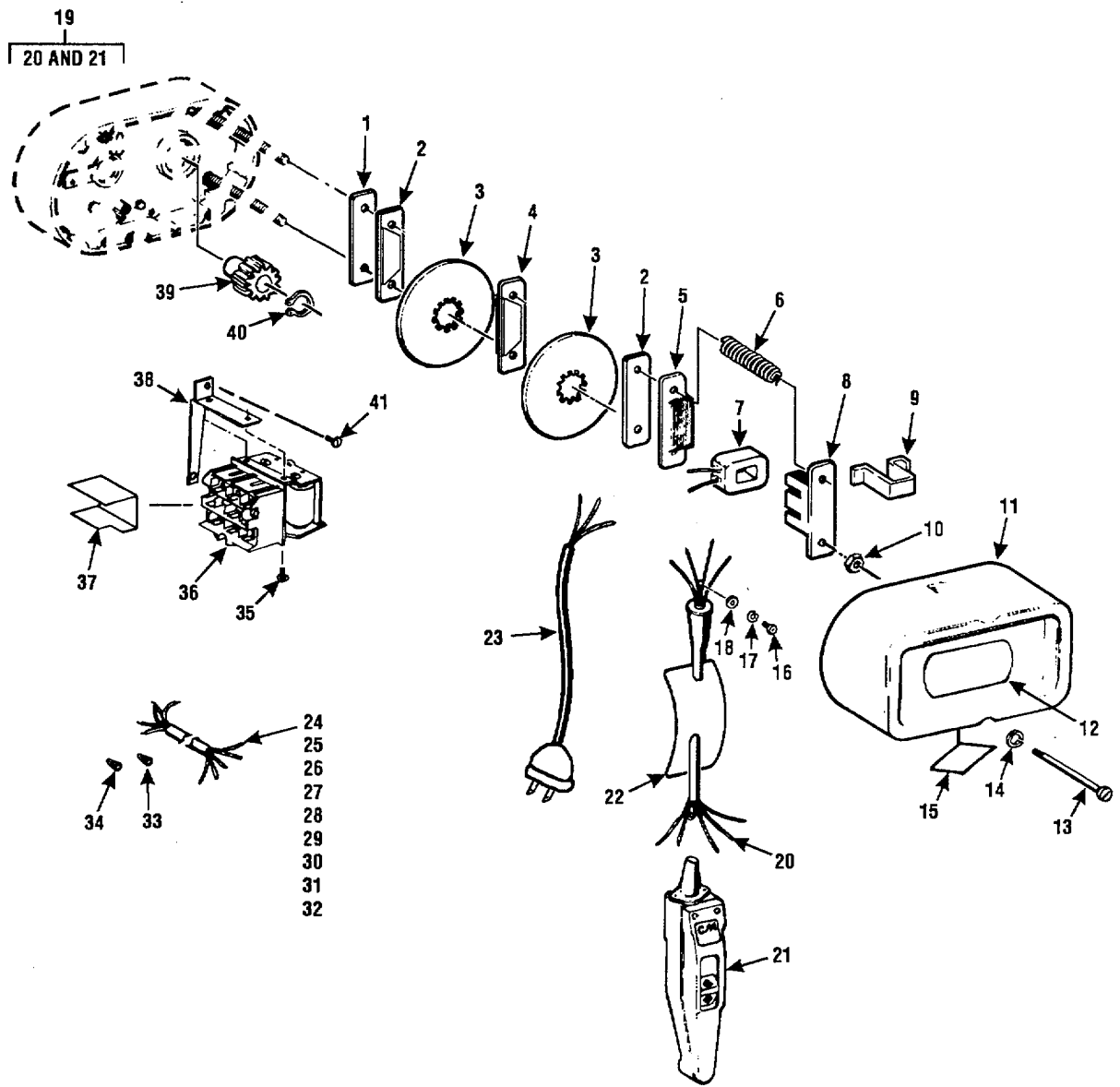

- | | | | |
|-----------------------|----------------------|-------------------|------------------------|
| 1. Brake Plate | 12. Label | 23. Power cord | 34. Wire Nut |
| 2. Friction Plate (2) | 13. Screw (2) | 24. Wire Lead | 35. Screw (2) |
| 3. Brake Disc (2) | 14. Lockwasher (2) | 25. Wire Lead | 36. Contactor Assembly |
| 4. Friction Plate | 15. Decal | 26. Wire Lead (3) | 37. Insulator |
| 5. Armature | 16. Screw | 27. Wire Lead | 38. Bracket |
| 6. Spring (2) | 17. Lockwasher | 28. Wire Lead | 39. Brake Hub |
| 7. Coil | 18. Washer | 29. Wire Lead | 40. Retaining Ring |
| 8. Field | 19. Control Station | 30. Wire Lead | 41. Screw |
| 9. Strap | 20. Cable | 31. Wire Lead | |
| 10. Nut (2) | 21. Control Assembly | 32. Wire Lead | |
| 11. Cover | 22. Tag | 33. Wire Nut (2) | |

Figure 4-3. Electric Hoist Assembly - Brake End.

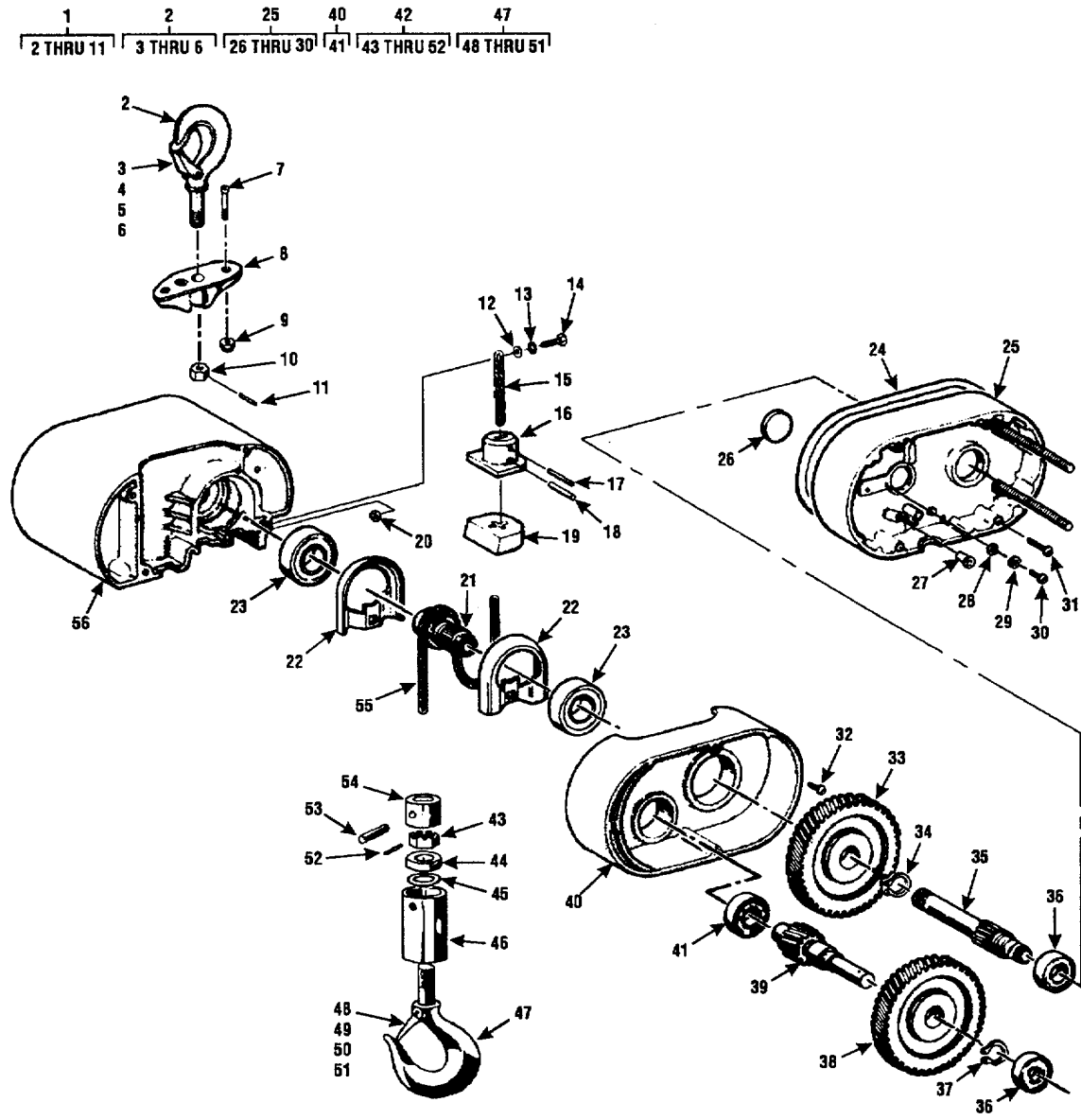

- | | | | |
|------------------------|---------------------|--------------------|-------------------|
| 1. Suspension Assembly | 15. Loose End Chain | 29. Lockwasher | 43. Nut |
| 2. Hook Assembly | 16. Block | 30. Screw | 44. Bearing |
| 3. Latch | 17. Pin | 31. Screw (3) | 45. Washer |
| 4. Screw | 18. Pin | 32. Screw (4) | 46. body |
| 5. Spring | 19. Block | 33. Gear | 47. Hook Assembly |
| 6. Locknut | 20. Nut | 34. Retaining Ring | 48. Latch |
| 7. Screw (2) | 21. Liftwheel | 35. Shaft & Pinion | 49. Screw |
| 8. Adapter | 22. Guide (2) | 36. Bearing | 50. Spring |
| 9. Nut (2) | 23. Bearing (2) | 37. Retaining Ring | 51. Nut |
| 10. Collar | 24. Gasket | 38. Protect | 52. Pin |
| 11. Pin | 25. Frame Assembly | 39. Pinion | 53. Pin |
| 12. Washer | 26. Plug | 40. Housing | 54. Block |
| 13. Lockwasher | 27. Plug (4) | 41. Bearing | 55. Load Chain |
| 14. Capscrew | 28. Washer | 42. Hook & Block | 56. Housing |

Figure 4-4. Electric Hoist Assembly - Gear and Hook Section

- (16) Remove pin (11) and nut (10) to remove upper hook assembly (2) from adapter (8).
- (17) If necessary, remove nut (6), screw (4), latch (3), and latch spring (5) from hook assembly (2).

e. Disassembly - Motor End (Figure 4-5).

NOTE

The motor end cover (4) is at end of hoist opposite from the end with power cord. When removing the cover (4), movement will be limited until wire leads are exposed and disconnected.

- (1) Remove two screws (1), lockwashers (2), and cover (4).

WARNING

CAPACITOR (17) MAY BE CHARGED. TO AVOID ELECTRICAL SHOCK, ENSURE THAT CAPACITOR HAS BEEN DISCHARGED BEFORE DISCONNECTING WIRE LEADS.

- (2) Discharge capacitor (17) by shorting across terminals. As they are exposed, tag and disconnect wire leads from terminals.
- (3) Carefully remove the rotor assembly (11) from the stator assembly (20). Remove wave washer (14) and spacer (15) from gear housing.
- (4) Remove retaining ring (12), bearing (13), and inner retaining ring (12) from rotor shaft.
- (5) If necessary for replacement of rotor (11) or centrifugal mechanism (7), use a bearing puller to remove centrifugal mechanism (7) and spacer (8) from other end of rotor shaft.
- (6) Remove screw (19) and mounting spring (18) that secures capacitor (17) to the gear housing.
- (7) Note the routing of leads from the stator and carefully pull stator assembly (20) from housing (56, Figure 4-4).

NOTE

If stator (20, Figure 4-5) will not slip easily from motor housing (58, Figure 4-4), tap on exterior of housing with a

brass drift while pulling on stator, or apply moderate heat to exterior of housing.

- (8) If necessary, remove pin (21) from stator.
- (9) Remove two screws (9) and stationary switch (6) from the cover (4).
- (10) Remove bearing (5) from cover (4) with bearing puller.

f. Disassembly - Control Station (Figure 4-6).

- (1) Remove four screws (9) and lift off cover assembly (10) and gasket (8).
- (2) Tag and disconnect wire leads from control cable (20, Figure 4-3). Remove screw (5, Figure 4-6) and flat washer (4) from eye of restraining cable that supports the control cable. Remove two screws (1) and pull control cable from case (16). Slide grommet (2) and retaining ring (3) from control cable.
- (3) Loosen screws (7) and remove pins (6), switches (14), and leaf springs (15).
- (4) Remove screw (11), terminal (12), and jumper assembly (13).

g. Cleaning and Inspection.

WARNING

DRY CLEANING SOLVENT (P-D-680) IS TOXIC AND FLAMMABLE. WEAR PERSONAL PROTECTIVE EQUIPMENT, TO INCLUDE NITRILE RUBBER GLOVES/APRONS AND A FULL FACE SHIELD; USE ONLY IN A WELL-VENTILATED AREA; AVOID CONTACT WITH SKIN, EYES, AND CLOTHES AND DO NOT BREATHE VAPORS. KEEP AWAY FROM HEAT OR FLAME. NEVER SMOKE WHEN USING SOLVENT. FLASH POINT FOR TYPE III SOLVENT IS 2000F. FAILURE TO DO SO MAY RESULT IN INJURY OR DEATH TO PERSONNEL. REFER TO WARNING S PAGE B FOR MORE INFORMATION.

- (1) Clean parts as follows:
 - (a) Clean friction plates (2 and 4, Figure 4-3) and insulator (37) with a clean dry cloth.

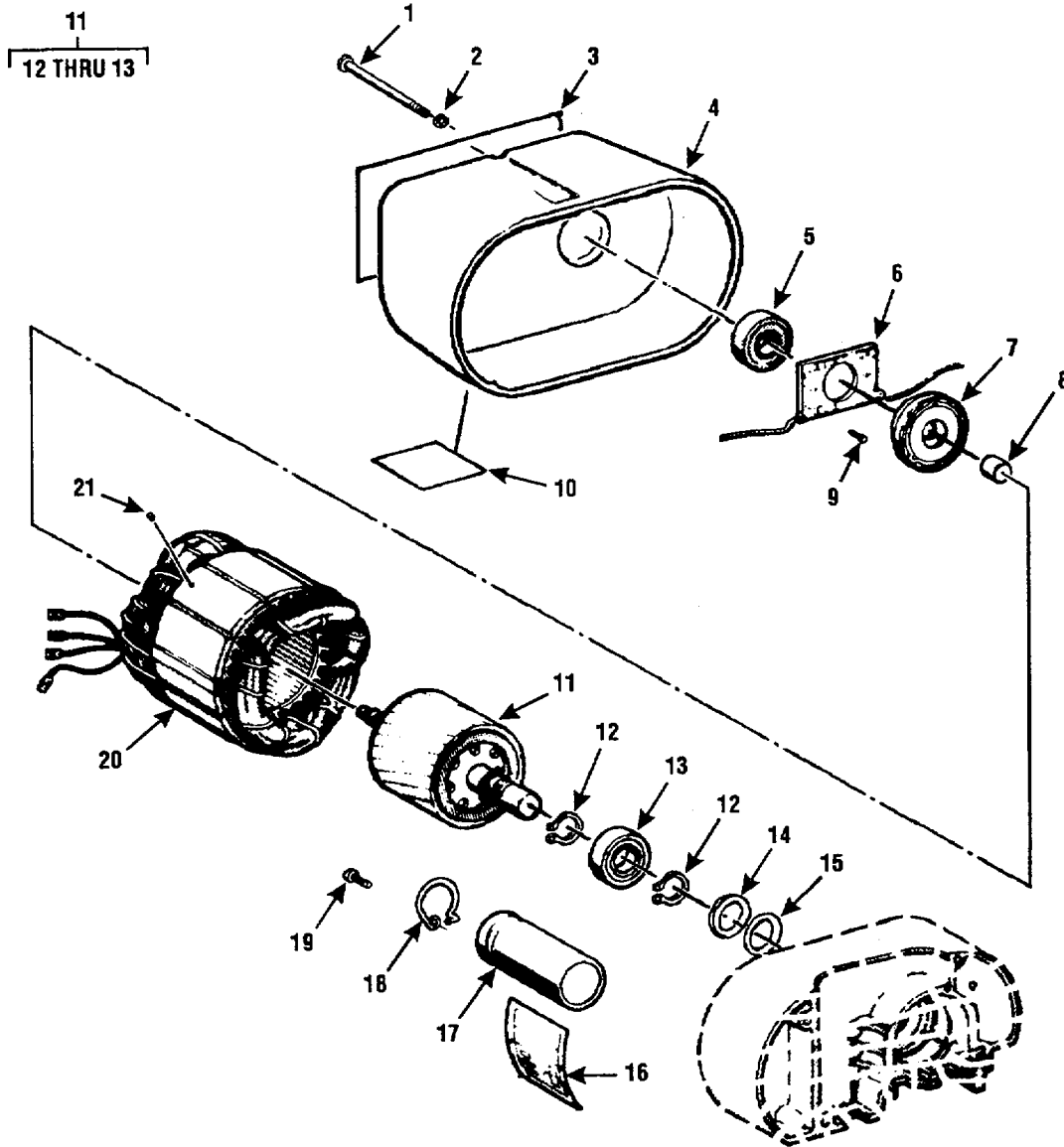

- | | | | |
|-------------------|------------------------|---------------|---------------------|
| 1. Screw (2) | 7. Centrifugal | 13. Bearing | 19. Screw |
| 2. Lockwasher (2) | 8. Spacer | 14. Washer | 20. Stator Assembly |
| 3. Label | 9. Screw (2) | 15. Spacer | 21. Pin |
| 4. cover | 10. Decal | 16. Label | |
| 5. Bearing | 11. Rotor Assembly | 17. Capacitor | |
| 6. Switch | 12. Retaining Ring (2) | 18. Spring | |

Figure 4-5. Electric Hoist Assembly - Motor End.

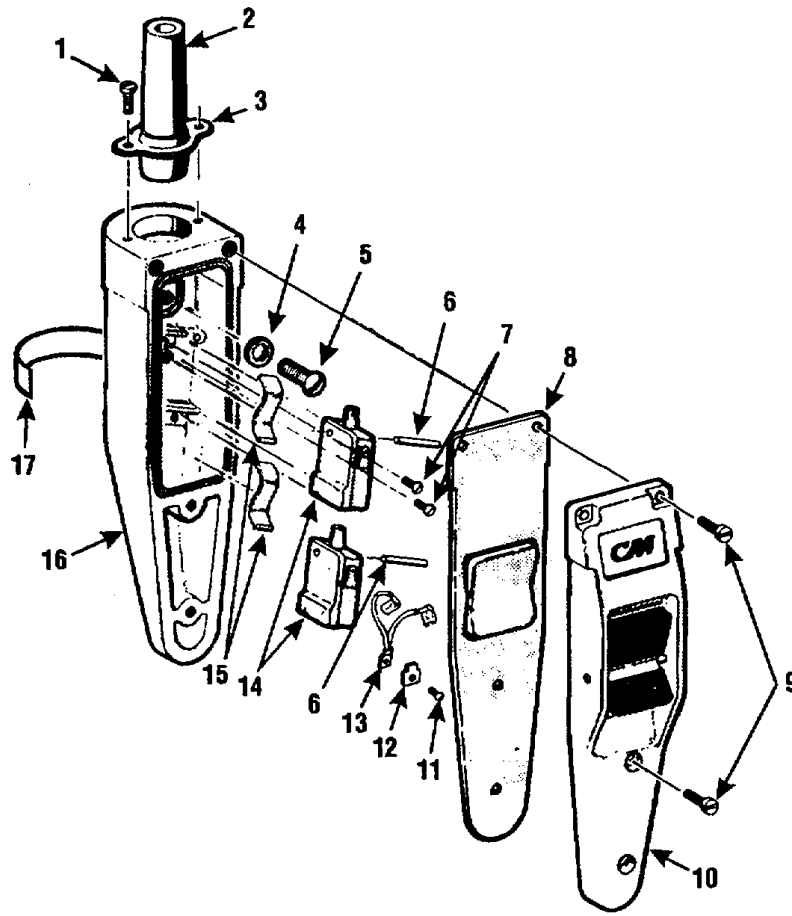

- | | | | |
|-------------------|--------------------|---------------------|-----------|
| 1. Screw (2) | 6. Pin | 11. Screw (1) | 16. Case |
| 2. Grommet | 7. Screw (2) | 12. Terminal | 17. Decal |
| 3. Retaining Ring | 8. Gasket | 13. Jumper Assembly | |
| 4. Washer | 9. Screw (4) | 14. Switch (2) | |
| 5. Screw | 10. Cover Assembly | 15. Leaf Spring (2) | |

Figure 4-6. Electric Hoist Assembly - Control Station

- (b) Clean exterior of coil (7), cable (20), power cord (23), wire leads (24-32), contactor assembly (36), switch (6, Figure 4-5), capacitor (17), stator assembly (20), grommet (2, Figure 4-6), gasket (8), jumper assembly (13), and switch (14) with a clean cloth dampened with water and dry parts thoroughly.
 - (c) Clean exterior of centrifugal (7, Figure 4-5) and rotor assembly (11) with cloth dampened in an approved cleaning solvent and dry thoroughly.
 - (d) Clean all other parts except bearings with an approved cleaning solvent and dry thoroughly.
- (2) Inspect chain guides (22, Figure 4-4) for wear, as evidenced by shiny areas, or burring where chain enters the hoist.
 - (3) Inspect each link of load chain (55) for wear at saddles of links (contract area), as evidenced by shiny areas. Inspect load chain (55) for stretched condition (Figure 4-7), checking over several sections of the chain. The diameter of new chain stock is 0.250 inch. The maximum allowable length over 19 links for used chain is 14-13/16 inches.
 - (4) Inspect friction plates (2 and 4, Figure 4-3) and brake discs (3) for evidence of excessive wear. Replace parts which have glassed or checked surfaces.

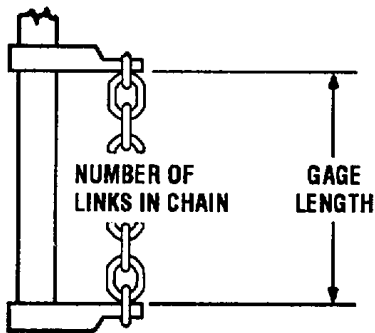

Figure 4-7. Chain Measurement Diagram.

- (5) Inspect electrical power cord (23), control cable (20) and all wire leads for damaged insulation.
- (6) Inspect contacts of contactor (36) and switch (6, Figure 4-5) for burned or other damaged condition.
- (7) Inspect all other parts for sign of wear, cracks or other damage.
- (8) Replace any part found to be damaged in any way.

- h. Assembly - Control Station (Figure 4-6).
 - (1) Secure jumper assembly (13) and terminal (12) to the case (16) with screw (11).
 - (2) Seat leaf springs (15) in case (16) as shown and secure switches (14) to case with pins (6). Tighten screws (7) to secure pins (6) in place.
 - (3) Slide retaining ring (3) and grommet (2) onto end of control cable (20, Figure 4-3). Insert end of leads of the control cable into the opening on end of case (16, Figure 4-6) and secure eye of control cable restraint with screw (5) and flat washer (4). Secure grommet (2) to case with two screws (1) and retaining ring (3).
 - (4) Refer to tags noted during disassembly and wiring diagram (Figure 4-8) to aid in making proper electrical connections.
 - (5) Seat gasket (8, Figure 4-6) into cover assembly (10) and secure the cover with four screws (9).

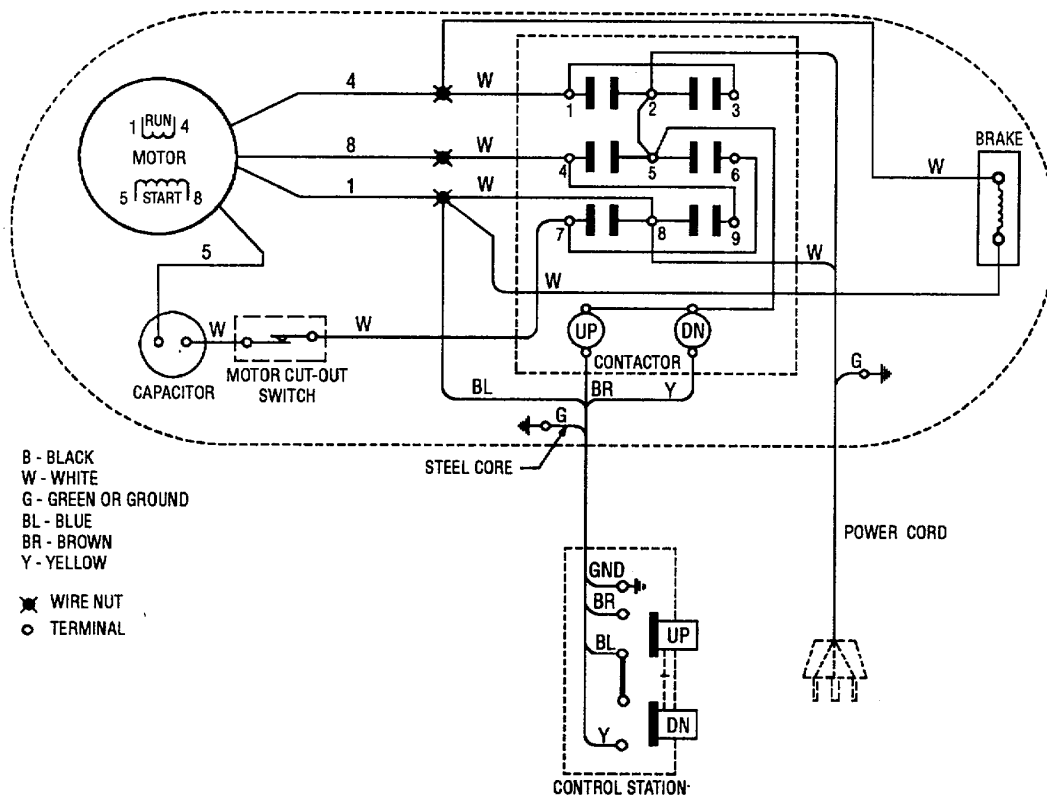

Figure 4-8. Hoist Wiring Diagram.

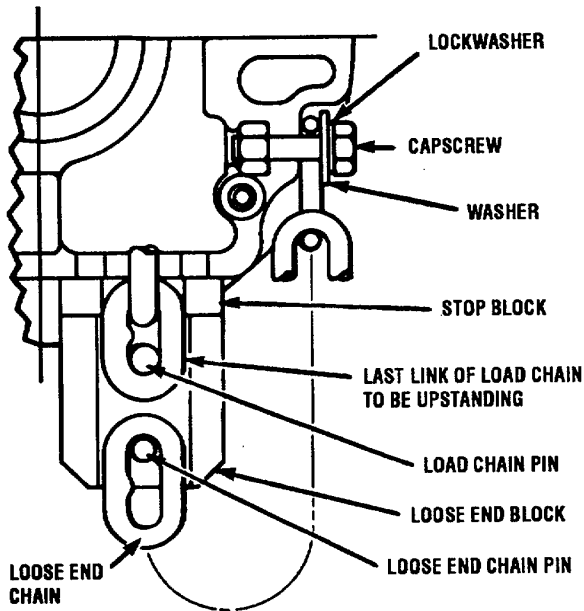

Figure 4-9. Chain Installation Diagram.

i. Assembly - Gear and Hook Section (Figure 4-4).

- (1) If removed, install latch (3) and latch spring (5), applying torque to the spring to keep the latch closed. Secure latch and spring with screw (4) and nut (6).
- (2) Install stem of upper hook assembly (2) into adapter (8), and secure with nut (10) and pin (11). Assemble screws (7) and Nuts (9) to adapter loosely.
- (3) Install bearings (23 and 41) in bores of motor housing (56) and gear housing (40), seating fully against shoulder.
- (4) Assemble chain (55) to liftwheel (21), with last link on loose end side of hoist an upstanding link and weld of up-standing links to outside of liftwheel (see Figure 4-9). Assemble the chain guides (22, Figure 4-4) to the liftwheel (21) and around lift chain (55), seating the guides firmly against each other with internal tab engaging the chain slot of liftwheel.
- (5) Seat assembled chain (55), liftwheel (21), and chain guides (22), with splined end of liftwheel up, into motor housing (56),

engaging bearing (23). Chain guides must engage the square boss of motor housing.

- (6) Install nut (20) in recess of motor housing (56), with nylock side of nut toward liftwheel (21).
- (7) Support assembled upper hook with nuts (9) in slots of motor housing. Carefully mate the motor housing (56) and gear housing (40), aligning liftwheel with bearing (23) in gear housing. Secure housings with four screws (32). Ensure that screws are tight.
- (8) Secure upper hook assembly (2) and adapter (8). Torque the screws (7) to 30-45 ft. lbs with 12-point socket and torque wrench.
- (9) Assemble protector (38), with lettering away from pinion, to intermediate pinion (39) and secure with retaining ring (37).
- (10) Install bearing (36) onto shoulder of intermediate pinion (39).
- (11) Install gear (33) onto liftwheel (21) and secure with retaining ring (34).
- (12) Install shaft and pinion assembly (35), meshing pinion teeth with gear of protector (38).
- (13) Install the intermediate pinion (39) with protector (38), carefully meshing pinion teeth with gear (33).
- (14) If removed, install plugs (27) and expansion plug (26) in frame assembly (25).
- (15) Install second bearing (36) into bore of housing (25), seating in bore nearest the brake studs.
- (16) Install flat washer (28), lockwasher (29), and screw (30) in frame assembly (25).
- (17) Assemble new gasket (24) on mating surface of gear housing (40) and carefully guide frame assembly (25) over ends of intermediate shaft (39) and shaft (35). Seat frame assembly against gasket (24) and secure with screws (31).

j. Assembly - Motor End (Figure 4-5).

- (1) Install bearing (5) in cover (4), seating fully against shoulder provided.
- (2) Position stationary switch (6) in cover (4) and secure with two screws (9).

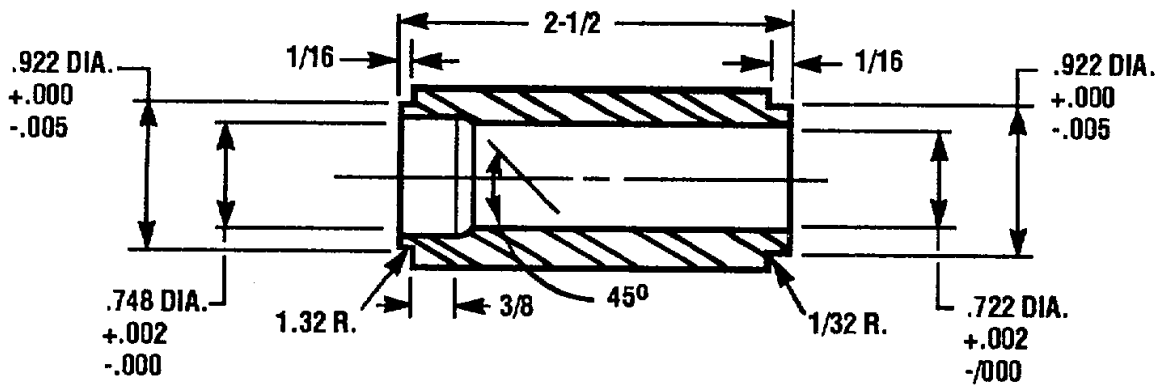

Figure 4-10. Press-In Tool Details.

- (3) If installing a new stator assembly (20), install pin (21).
- (4) Carefully install the stator into the motor housing (56, Figure 4-4), engaging slot in housing with pin (21, Figure 4-5).

CAUTION

When installing the centrifugal mechanism (7), do not allow more than 3000 pounds of force to be applied. Damage may result should greater force be used.

- (5) Install spacer (8) on rotor shaft, and using tool described in figure 4-10, press the centrifugal mechanism (7, Figure 4-5) on the rotor shaft until seated against spacer (8) as shown in figure 4-11.

NOTE

Centrifugal mechanism must be installed with spring loaded side facing away from rotor windings.

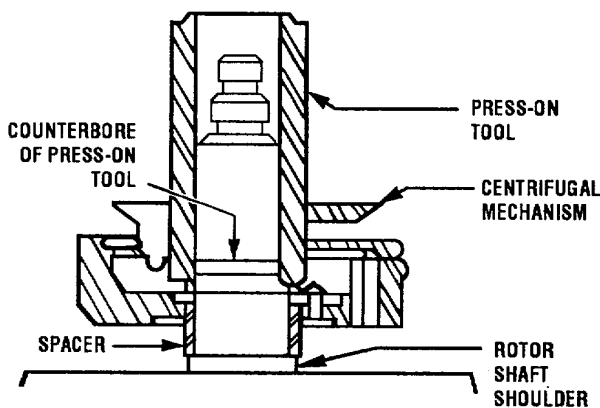

Figure 4-11. Installing Centrifugal.

- (6) Install the capacitor (17), securing with mounting spring (18) and screw (19).
- (7) Install flat washer (15) and wave washer (14) in housing on top of bearing (23, Figure 4-4).
- (8) Install inner retaining ring (12, Figure 4-5) into inner groove of rotor shaft (11). Install bearing (13) and outer retaining ring (12).
- (9) Carefully install the rotor assembly (11) into the stator assembly (20), seating the rotor shaft into bearing (23, Figure 4-4).
- (10) Referring to tags noted during disassembly and wiring diagram (Figure 4-8), make all electrical connections while installing the assembled cover to the motor housing.
- (11) With rotor shaft seated into the splines of the shaft (35, Figure 4-4), secure cover (4, Figure 4-5) with screws (1) and lockwashers (2). Tighten screws (1) to 48 in-lbs torque.

k. Assembly - Brake End (Figure 4-3).

- (1) If removed, install coil (7) to field (8); securing with strap (9).
- (2) Install brake plate (1) and a friction plate (2) over studs of frame assembly and seat into housing.

NOTE

When installing the friction plates (2 and 4), always install with wide side of pads facing the brake hub (39) and the pads facing the brake discs (3).

- (3) Install a brake disc (3), engaging splines of brake hub, friction plate (4) a second brake disc (3) and a second friction plate (2).

- (4) Install brake armature (5) and two springs (6). Compress the springs and install assembled field (8), securing with nuts (10). Tighten nuts to seat field (8) with a 0.020-0.030 inch gap to armature (5).
- (5) If removed, install contactor (36) to bracket (38), securing with screws (35).
- (6) Install assembled bracket and contactor to frame assembly with screw (41), at upper mounting hole of bracket.
- (7) Secure control cable and ground lead of power cable (23) to boss in frame assembly with flat washer (18), lockwasher (17), and screw (16).
- (8) Refer to noted tags on control and power cables (22 and 23) and wiring diagram (Figure 4-8) and connect all electrical leads. Carefully coil all long leads without sharp bends and tape to ensure leads will not touch brake discs.
- (9) Carefully install cover (11, Figure 4-3) without pinching wire leads, securing with two screws (13) and lockwashers (14).

I. Assembly - Lower Hook Assembly and Loose End Chain (Figure 4-4)

- (1) If removed, install latch (48) and latch spring (50), applying torque to the spring to keep the latch closed. Secure latch and spring with screw (49) and nut (51).
- (2) Assemble lower hook (47), body (46), washer (45), and thrust bearing (44).

Secure with castle nut (43), tightening nut firmly and then back off nut to align slot in nut with hole through stem of hook (47) and install pin (52).

- (4) Position the lower hook body (46) in a vice with the larger pin hole facing up. Slide last link of load chain in slot of block (54) and position block into lower hook body, ensuring that bore is with the pin hole in hook body. Install pin (53), small end first, and seat pin with hammer until flush with surface of hook body.
 - (5) Install loose end chain (15) to loose end block (16) and secure with pin (17).
 - (6) Install stop block (19) onto end of load chain (55) and insert last link into the loose end block (16). Secure the load chain with pin (18).
 - (7) Secure end of loose end chain (15) to motor housing (56) with capscrew (14), lockwasher (13), and flat washer (12).
- m. Installation.
- (1) Install the electric hoist (2, Figure 2-12) to the melter by hooking the upper suspension hook to the trolley.
 - (2) Install the drum sling (3) in the lower hook assembly as shown in figure 2-12.
 - (3) Connect the power cord to an approved 110 volt power supply furnished for the melters.

Section V. - PREPARATION FOR SHIPMENT OR STORAGE

5-1. Preparation for Shipment.

NOTE

A suitable lifting device, of sufficient capacity, (approximately 12, 100 lbs.) must be available for disassembly, packing and loading of the asphalt melter on carrier.

- a. Remove the drum sling (3, figure 2-12), and hoist (2) from melter.
- b. Remove the trolley (1) as follows:
 - (1) Remove one cotter pin (figure 2-13), clevis pin and adjusting collar.
 - (2) Remove the side #1 from load bar and remove the rest of trolley from trolley beam.
- c. Remove the discharge chute as follows:
 - (1) Refer to figure 2-10, and fold the barrel retainer onto the chute floor.
 - (2) Pivot both legs with leg extensions up and catch in the open bracket to secure for moving.
 - (3) Attach a suitable hoist and lift the discharge chute from the rear of the melter and set aside in the work area so as not to obstruct access to the rest of the melter.
- d. Remove the hand winches as follows:
 - (1) Remove the wire rope clip (figure 2-11), to release the wire rope from the door lift ring.
 - (2) Crank the winch to reeve the wire rope onto the winch reel. Tape the wire rope to prevent roe from unreeving.
 - (3) Remove three nuts, lockwashers, flat washers and capscrews and remove hand winch from brake.
 - (4) Repeat steps 1 through 3 to remove rear door winch.
- e. Remove guard rails as follows (figure 2-9):
 - (1) Remove capscrews (6), lockwashers (4) and nuts (5) that secure left side rail (7), front corner rail (8), front rail support (9), right side railing (11), and latter railing (13).
 - (2) Remove capscrews (14), lockwashers (4), and nuts (5) that secure rail supports (10 and 12) to the platform.
 - (3) Remove nuts (2) and lockwashers (1) that secure the rear rail corners (3) to the tunnel.
- f. Remove load platform upper structure as follows (figure 2-8):
 - (1) Remove capscrews (7), nuts (2) and lockwashers (3) that secure trolley beam (5). Remove beam (5) from structure.
 - (2) Remove capscrews (10), nuts (8), and lockwashers (9) that secure cross beams (1 and 4). Remove the cross beams (1 and 4).
 - (3) Carefully supporting each up-right support (6), remove the capscrews (7), nuts (2) and lockwashers (3) that secure the supports to the platform. Remove each support from platform.
- g. Remove the platform as follows (figure 2-7):
 - (1) Remove capscrews (3), nuts (4) and lockwashers (5) that secure ramp brackets (2) and load ramp (1) to the platform (13). Remove the load ramp (1).
 - (2) Remove capscrews (8 and 9), nuts (4), and lockwashers (5) that secure the ladder brace (10) and ladder (7) to platform (13) and leg (6). Remove the ladder (7).
 - (3) Remove capscrews (8 and 3), nuts (4), and lockwashers (5) that secure platform braces (12) to legs (8) and bracket on storage tank. Remove braces (12).
 - (4) Attach a suitable hoist to support the platform (13). Remove capscrews (8), nuts (4), and lockwashers (5) that secure the legs (6) to the platform (13). Remove the legs (6) and extensions (11).
 - (5) Remove capscrews (9), nuts (4), and lockwashers (5) that secure the platform (13) to the brackets on storage tank standoff tube. With hoist lift the platform (13) from the melter and set aside.

- h. Remove hot oil and asphalt piping as follows:
 - (1) For installations with a single unit installed, refer to figure 2-5, and disconnect components and remove from melter.
 - (2) For installations with multiple units installed, refer to figure 2-6, and disconnect components and remove from melter.
 - (3) Refer to figure 2-4 and disconnect and remove pipe assemblies (2, 6, 19 and 22) and gate valves (7).

NOTE

The asphalt jacketed valve (16, Figure 2-4) and 3/4 inch hot oil hoses (11) and piping need not be removed for shipping or storage purposes.

- (4) Install cover (14) onto connector (13) and install covers (9, figure 2-5) on exposed flanges of oil piping welded to storage tank.
- (5) Install pipe caps (2, figure 2-3) on oil piping of tunnel (1).
- i. Remove the front rainshield (3, figure 2-3), side rainshields (4, 5, 11, and 12) in that order, and rear rainshield (13).
- j. Attach a four-point sling to the lifting eyes on top of the tunnel and lift (approximately 5000 lbs.) the tunnel off the storage tank with a suitable lifting device. Place the tunnel on wood blocks, positioned to support the tunnel support rails.
- k. Clean the melter and piping (paragraph 4-1).
 - l. Cap or tape all pipe sections to prevent entry of foreign material.
- m. Stow all items listed in Table 2-2 in toolbox.
- n. Stow all items listed in Table 2-1 in wood crate and place inside the tunnel.
- o. Stow the trolley and electric hoist in a suitable box that will fit inside the tunnel.
- p. Open the tunnel doors and secure with blocking. Stow the storage crate, ladder, load ramp, trolley, and electric hoist inside the tunnel and close the doors.
- q. Remove the four holddown bars (9, figure 2-3), securing the tunnel support beams (8) to the storage tank. Lift out the two tunnel support beams.
- r. Attach a four-point sling to the lifting eyes on top of the tunnel and lift (approximately 5000 lbs.) the tunnel off the blocking and carefully lower it

into the storage tank with a suitable lifting device. For travel by rail, center the tunnel in tank as much as possible and provide wood blocking at four corners of the tunnel beside the front and rear door frames. Blocking should be sufficient to prevent tunnel movement within the storage tank.

- s. Re-install the tunnel support beams in the storage tank, securing with the holddown bars (see Figure 2-1).
- t. Attach a four-point sling to the load platform and lift (approximately 150 lbs.) the platform and place on top of the tunnel, positioned as shown in figure 2-1.
- u. Attach a four-point sling to the discharge chute and lift (approximately 250 lbs.) the chute, placing it over the platform on top of the tunnel as shown in figure 2-1. Secure the discharge chute and load platform to the top of the asphalt melter tunnel with minimum 1.25 inch strapping material secured to the front and rear standoff pipes.

CAUTION

DO NOT attach lifting sling to lift eyes on top of tunnel or to the stand-off guards at front and rear of unit. Attach lifting sling to eyes in the front and rear of the skid rails, guiding the sling cables over the stand-off guards at each end of unit. Ensure that sling is positioned so that hooks or shackles will not contact the piping components at front of storage tank. Damage to fixed piping of storage tank could result.

- v. Attach a suitable lifting sling to all four eyes of skid rails, with cables guided over the top of the stand-off guards at front and rear of the unit. Lift the unit onto the carrier bed.

5-2. Transporting.

- a. The asphalt melter may be transported by any carrier of adequate size and capacity (see paragraph 1-2, for weight and shipping dimensions).
- b. The unit must be mounted on deck of carrier with adequate blocking on all four sides and tied down with cables or chain through the four eyes in the skid rails.

5-3. Storage.

- a. Disassemble and pack the melter as instructed in "Preparation For Shipment", (paragraph 5-1).
- b. Elevate the unit off the ground and support with suitable wood blocking under skid rails.
- c. If unit is to be stored outdoors for any extended period of time, completely cover the unit with a tarp.

5-3 (5-4 Blank)

**APPENDIX A
UNIT, DIRECT SUPPORT, AND
GENERAL SUPPORT MAINTENANCE
REPAIR PARTS AND SPECIAL TOOLS LIST**

SECTION I. INTRODUCTION

1. Scope

This RPSTL lists and authorizes spares and repair parts; special tools; special test, measurement, and diagnostic equipment (TMDE); and other special support equipment required for performance of Unit, Direct Support, and General Support Maintenance of the Asphalt Melter, Model STMD-3000A. It authorizes the requisitioning, issue, and disposition of spares, repair parts and special tools as indicated by the source, maintenance and recoverability (SMR) codes.

2. General.

In addition to Section I. Introduction, this Repair Parts and Special Tools List is divided into the following sections:

- a. Section II. Repair Parts List. A list of spares and repair parts authorized by this RPSTL for use in the performance of maintenance. The list also includes parts which must be removed for replacement of the authorized parts. Parts lists are composed of functional groups in ascending alphanumeric sequence, with the parts in each group listed in ascending figure and item number sequence. Bulk materials are listed in item name sequence. Repair kits are listed separately in their own functional group within Section II. Repair parts for repairable special tools are also listed in the section. Items listed are shown on the associated illustration(s)/figure(s).
- b. Section III. Special Tools List. A list of special tools, special TMDE, and other special support equipment authorized by this RPSTL (as indicated by Basis of Issue (BOI) information in DESCRIPTION AND USABLE ON CODE column) for the performance of maintenance.
- c. Section IV Cross-reference Indexes. A list, in National Item Identification Number (NIIN) sequence, of all National stock numbered items appearing in the listing, followed by a list in alphanumeric sequence of all part numbers appearing; in the listings. National stock numbers and part numbers are cross-referenced to each illustration, figure and item number appearance. The figure and item number index lists figure and item numbers in alphanumeric

sequence and cross-references NSN, CAGEC and part numbers.

3. Explanation of Columns (Sections II and III).

- a. ITEM NO. (Column (1)). Indicates the number used to identify items called out in the illustration.
- b. SMR CODE (Column (2)). The Source, Maintenance, and Recoverability (SMR) code is a 5-position code containing supply/requisitioning information, maintenance category authorization criteria, and disposition instruction, as shown in the following breakout:

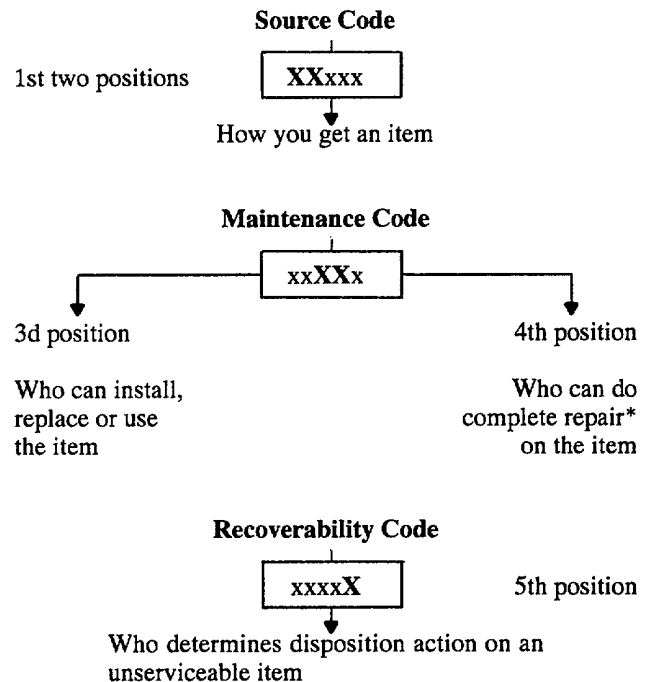

* Complete Repair: Maintenance capacity, capability, and authority to perform all corrective maintenance tasks of the "Repair" function in a use/user environment in order to restore serviceability to a failed item.

- (1) Source Code. The source code tells you how to get an item needed for maintenance, repair, or overhaul of an end item/equipment. Explanations of source codes follows:

<u>Code</u>	<u>Application/Explanation</u>
PA	Stocked items; use the applicable NSN to request/requisition items with these source codes. They are authorized to the category indicated by the code entered in the 3d position of the SMR code.
PB	
PC**	
PD	
PE	
PF	
PG**	Items coded PC are subject to deterioration.
KD	Items with these codes are not to be requested/requisitioned individually. They are part of a kit which is authorized to the maintenance category indicated in the 3d position of the SMR code. The complete kit must be requisitioned and applied.
KF	
KB	
MO-(Made at UM/AVUM Level)	Items with these codes are not to be requested/requisitioned individually.
MF-(Made at DS/AVUM Level)	They must be made from bulk material which is identified by the part number in the DESCRIPTION AND USABLE ON CODE (UOC) column and listed in the Bulk Material group of the repair parts list in this RPSTL. If the item is Repair authorized to you by the 3d position code of the SMR code, but if the source code indicates it is made at a higher level, order the item from the higher level of maintenance.
ML-(Made at Specialized Act (SRA))	
MD-(Made at Depot)	
AO-(Assembled by UM/AVUM Level)	Items with these codes are not to be requested/requisitioned individually.
AF-(Assembled by DS/AVIM Level)	The parts that make up the assembled item must be requisitioned or fabricated and assembled at the level of maintenance indicated by the source code. If the 3d position code of the SMR code authorizes you to replace the but the item, source code indicates the item is assembled at a higher level, order the item from the higher level of maintenance.
AH-(Assembled by GS Category)	
AL-(Assembled by SRA)	
AD-(Assembled by Depot)	
XA-	Do not requisition an "XA"-coded item. Order its next higher assembly. (Also, refer to the NOTE below).
XB-	If an "XB" item is not available from salvage, order it using the CAGEC and part number given.
XC-	Installation drawing, diagram, instruction sheet, field service drawing, that is identified by the manufacturer's part number.

XD- Item is not stocked. Order an "XD"-coded item through normal supply channels using the CAGEC and part number given, if no NSN is available.

NOTE: Cannibalization or controlled exchange, when authorized, may be used as a source of supply for items with the above source codes, except for those source coded "XA" or those aircraft support items restricted by requirements of AR 700-42.

(2) Maintenance Code. Maintenance codes tells you the level(s) of maintenance authorized to USE and REPAIR support items. The maintenance codes are entered in the third and fourth positions of the SMR Code as follows:

(a) The maintenance code entered in the third position tells you the lowest maintenance level authorized to remove, replace, and use an item. The maintenance code entered in the third position will indicate authorization to one of the following levels of maintenance.

<u>Code</u>	<u>Application/Explanation</u>
C -	Crew or operator maintenance done within unit or aviation unit maintenance.
O -	Unit maintenance or aviation unit category can remove, replace, and use the item.
F -	Direct support or aviation intermediate level can remove, replace, and use the item.
H -	General support level can remove, replace, and use the item.
L -	Specialized repair activity can remove, replace, and use the item.
D -	Depot level can remove, replace, and use the item.

(b) The maintenance code entered in the fourth position tells whether or not the item is to be repaired and identifies the lowest maintenance level with the capability to do complete repair (i.e., perform all authorized repair functions.) (NOTE: Some limited repair may be done on the item at a lower level of maintenance, if authorized by the Maintenance Allocation Chart (MAC) and SMR codes.) This position will contain one of the following maintenance codes.

<u>Code</u>	<u>Application/Explanation</u>
O -	Unit maintenance or aviation unit is the lowest level that can do complete repair of the item.
F -	Direct support or aviation intermediate is the lowest level that can do complete repair of the item.
H -	General support is the lowest level that can do complete repair of the item.

- L - Specialized repair activity is the lowest level that can do complete repair of the item.
- D - Depot is the lowest level that can do complete repair of the item.
- Z - Non-repairable. No repair is authorized.
- B - No repair is authorized. (No parts or special tools are authorized for the maintenance of a "B" coded item). However, the item may be reconditioned by adjusting, lubricating, etc., at the user level.

(3) Recoverability Code. Recoverability codes are assigned to items to indicate the disposition action on unserviceable items. The recoverability code is entered in the fifth position of the SMR Code as follows:

<u>Code</u>	<u>Application/Explanation</u>
Z-	Non-repairable item. When unserviceable, condemn and dispose of the item at the level of maintenance shown in 3d position of SMR Code.
O -	Reparable item. When uneconomically repairable, condemn and dispose of the item at unit maintenance or aviation unit level.
F -	Reparable item. When uneconomically repairable, condemn and dispose of the item at the direct support or aviation intermediate level.
H -	Reparable item. When uneconomically repairable, condemn and dispose of the item at the general support level.
D -	Reparable item. When beyond lower level repair capability, return to depot. Condemnation and disposal of item not authorized below depot level.
L -	Reparable item. Condemnation and disposal not authorized below specialized repair activity (SRA).
A -	Item requires special handling or condemnation procedures because of specific reasons (e., g. precious metal content, high dollar value, critical material, or hazardous material). Refer to appropriate manuals/directives for specific instructions.

c. CAGEC (Column (3)). The Commercial And Government Entity Code (CAGEC) is a 5-digit alphanumeric code which is used to identify the manufacturer, distributor, or Government agency, etc., that supplies the item.

d. PART NUMBER (Column (4)). Indicates the primary number used by the manufacturer (individual, company, firm, corporation, or Government activity), which controls the design and characteristics of the item by means of its engineering drawings, specifications, standards, and inspection requirements to identify an

item or range of items.

NOTE: When you use a NSN to requisition an item, the item you receive may have a different part number from the part ordered.

e. DESCRIPTION AND USABLE ON CODE (UOC) (Column (5)). This column includes the following information: (1) The Federal item name and, when required, a minimum description to identify the item.

(2) The physical security classification. Not applicable.

(3) Items that are included in kits and sets are listed below the name of the kit or set on Figure KIT.

(4) Spare/repair parts that make up an assembled item are listed immediately following the assembled item line entry.

(5) Part numbers for bulk materials are referenced in this column in the line item entry for the item to be manufactured/fabricated.

(6) When the item is not used with all serial numbers of the same model, the effective serial numbers are shown on the last line(s) of the description (before UOC). Not applicable.

(7) The usable on code, when applicable (see paragraph 5, Special information).

(8) In the Special Tools List section, the basis of issue (BOI) appears as the last line(s) in the entry for each special tool, special TMDE, and other special support equipment. When density of equipments supported exceeds density spread indicated in the basis of issue, the total authorization is increased proportionately.

(9) The statement "END OF FIGURE" appears just below the last item description in Column 5 for a given figure in both Section II and Section III.

f. QTY (Column (6)). The QTY (quantity per figure column) indicates the quantity of the item used in the breakout shown on the illustration figure, which is prepared for a functional group, subfunctional group, or an assembly. A "V" appearing in this column in lieu of a quantity indicates that the quantity is variable and the quantity may vary from application to application.

4. Explanation of Columns (Section IV).

a. NATIONAL STOCK NUMBER (NSN) INDEX.

(1) STOCK NUMBER column. This column lists the NSN by National item identification number (NIIN) sequence. The NIIN consists of the last nine digits of the NSN (i.e., 5305-01-674-1467). When using this column to NIIN locate an item, ignore the first 4 digits of the NSN. However, the complete NSN should be used when ordering items by stock number.

(2) FIG. column. This column lists the number of the Figure where the item is identified/located. The figures are in numerical order in Section II and Section III.

(3) ITEM column. The item number identifies the item associated with the figure listed in the adjacent FIG. column. This item is also identified by the NSN listed on the same line.

b. PART NUMBER INDEX. Part numbers in this index are listed by part number in ascending alphanumeric sequence (i.e., vertical arrangement of letter and number combination which places the first letter or digit of each group in order A through Z, followed by the numbers 0 through 9 and each following letter or digit in like order).

(1) CAGEC column. The Commercial And Government Entity Code (CAGEC) is a 5-digit alphanumeric code used to identify the manufacturer, distributor, or Government agency, etc., that supplies the item.

(2) PART NUMBER column. Indicates the primary number used by the manufacturer (individual, firm, corporation, or Government activity), which controls the design and characteristics of the item by means of its engineering drawings, specifications, standards, and inspection requirements to identify an item or range of items.

(3) STOCK NUMBER column. This column lists the NSN for the associated part number and manufacturer identified in the PART NUMBER and CAGEC columns to the left.

(4) FIG. column. This column lists the number of the figure where the item is identified/located in Section II and III.

(5) ITEM column. The item number is that number assigned to the item as it appears in the figure referenced in the adjacent figure number column.

c. FIGURE AND ITEM NUMBER INDEX.

(1) FIG. column. This column lists the number of the figure where the item is identified/located in Section II and III.

(2) ITEM column. The item number is that number assigned to the item as it appears in the figure referenced in x S, the adjacent figure number column.

(3) STOCK NUMBER column. This column lists the NSN for the item.

(4) CAGEC column. The Commercial And Government Entity Code (CAGEC) is a 5-digit alphanumeric code used to identify the manufacturer, distributor, or Government agency, etc., that supplies the item.

(5) PART NUMBER column. Indicates the primary number used by the manufacturer (individual, firm, corporation, or Government activity), which controls the design and characteristics of the item by means of its engineering drawings, specifications standards, and inspection requirements to identify an item or range of items.

5. Special Information.

a. USABLE ON CODE. The usable on code appears in the lower left corner of the Description column heading.

Usable on codes are shown as "UOC " in the Description Column (justified left) on the first line applicable item description/nomenclature. Uncoded items are applicable to all models. Identification of the usable on codes used in the RPSTL are:

<u>Code</u>	<u>Used On</u>
Not Applicable	

b. FABRICATION INSTRUCTIONS. Bulk materials required to manufacture items are listed in the Bulk Material Functional Group of this RPSTL. Part numbers for bulk materials are also referenced in the description column of the line item entry for the item to be manufactured/fabricated. Detailed fabrication instructions for items source coded to be manufactured or fabricated are found in the maintenance portion of this manual.

c. ASSEMBLY INSTRUCTION. Detailed assembly instructions for items source coded to be assembled from component spare/repair parts are found in the maintenance portion of this manual. Items that make up the assembly are listed immediately following the assembly item entry or reference is made to an applicable figure.

d. KITS. Line item entries for repair parts kits appear in group 9401 in Section II of this Appendix.

e. INDEX NUMBERS. Items which have the word BULK in the figure column will have an index number shown in the item number column. This index number is a cross-reference between the National Stock Number/Part Number Index and the bulk material list in Section II.

6. How to Locate Repair Parts.

a. When National Stock Number or Part Number is Not Known.

(1) First. Using the table of contents, determine the assembly group or subassembly group to which the item belongs. This is necessary since figures are prepared for assembly groups and subassembly groups, and listings are divided into the same groups.

(2) Second. Find the figure covering the assembly group or subassembly group to which the item belongs.

(3) Third. Identify the item on the figure and use the Figure and Item Number Index to find the NSN.

b. When National Stock Number or Part Number is Known.

(1) First. Using the National Stock Number or Part Number Index, find the pertinent National Stock Number or Part Number. The NSN index is in National Item Identification Number (NIIN) sequence (see 4.a(1)). The part numbers in the Part Number index are listed in

ascending alphanumeric sequence (see 4.b). Both indexes cross-reference you to the illustration figure and item number of the item you are looking for.

(2) Second. Turn to the figure and item number, verify that the item is the one you're looking for, then locate the item number in the repair parts list for the figure.

7. Abbreviations.

<u>Abbreviations</u>	<u>Explanation</u>
AVIM	Aviation Intermediate Maintenance
AVUM	Aviation Unit Maintenance
BOI	Basis of Issue
DS	Direct Support
GS	General Support
MAC	Maintenance Allocation Chart
MFD	Manufactured
NIIN	National Item Identification Number (consists of the last 9 digits of the NSN)
NSN	National Stock Number
RPSTL	Repair Parts and Special Tools List
SMR	Source, Maintenance, and Recoverability
TMDE	Test, Measurement and Diagnostic Equipment
UM	Unit Maintenance
UOC	Usable on Code

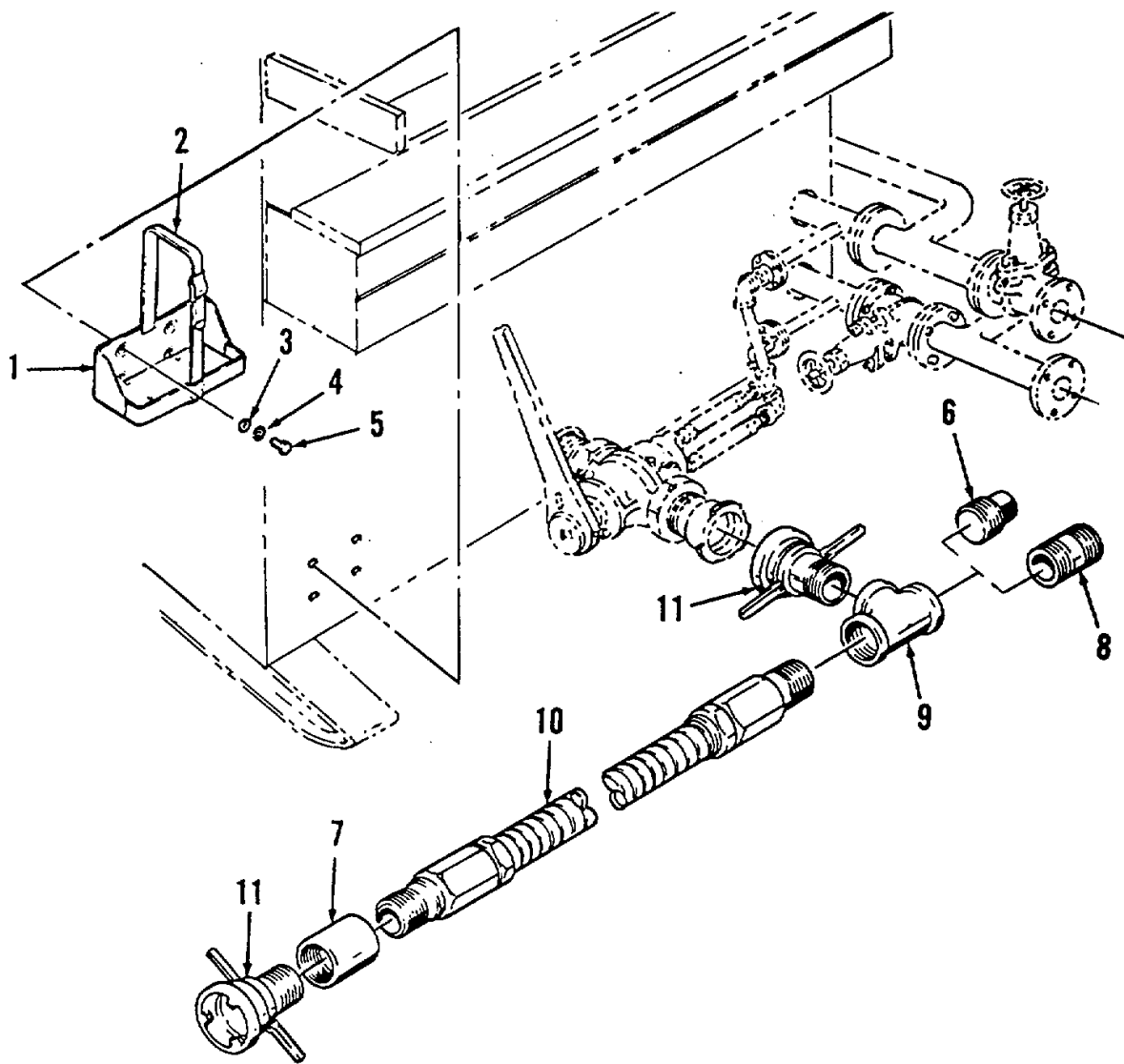

Figure 1. Accessory Items, Asphalt Hose

SECTION II					
(1)	(2)	(3)	(4)	(5)	(6)
ITEM NO	SMR CODE	CAGEC	PART NUMBER	DESCRIPTION AND USABLE ON CODES (UOC)	QTY
GROUP 22 BODY CHASSIS AND HULL ACCESSORY ITEMS					
GROUP 2202 ACCESSORY ITEMS					
FIG. 1 ACCESSORY ITEMS, ASPHALT HOSE					
1	PAOZZ	19207	6566675	BRACKET, VEHICULAR C	1
2	PAOZZ	19207	8690527	STRAP, WEBBING	1
3	PAOZZ	96906	MS27183-14	WASHER, FLAT 3/8 INCH	4
4	PAOZZ	81718	H2525M	WASHER, LOCK 3/8 INCH SPLIT	4
5	PAOZZ	96906	MS90725-55	SCREW, CAP, HEXAGON H 3/8-16UNC-2A X..... 1/2 INCH LONG, GRADE 5.....	4
6	XBOZZ	96906	MS51884-21	PLUG, PIPE 3 INCH NPT, SQUARE HEAD	1
7	PAOZZ	96906	MS39233-9B	COUPLING, PIPE 2 INCH NPT	1
8	PAOZZ	96906	MS51953-241B	NIPPLE, PIPE 3 INCH NPT X 3 INCH	1
9	PAOZZ	96906	MS14303-2P48	TEE, PIPE 3 INCH NPT	1
10	PAOZZ	11740	3000-9	HOSE ASSEMBLY, METAL.....	1
11	PAOZZ	41592	245SS-HOSE END-3 IN	COUPLING HALF, QUICK	2

END OF FIGURE

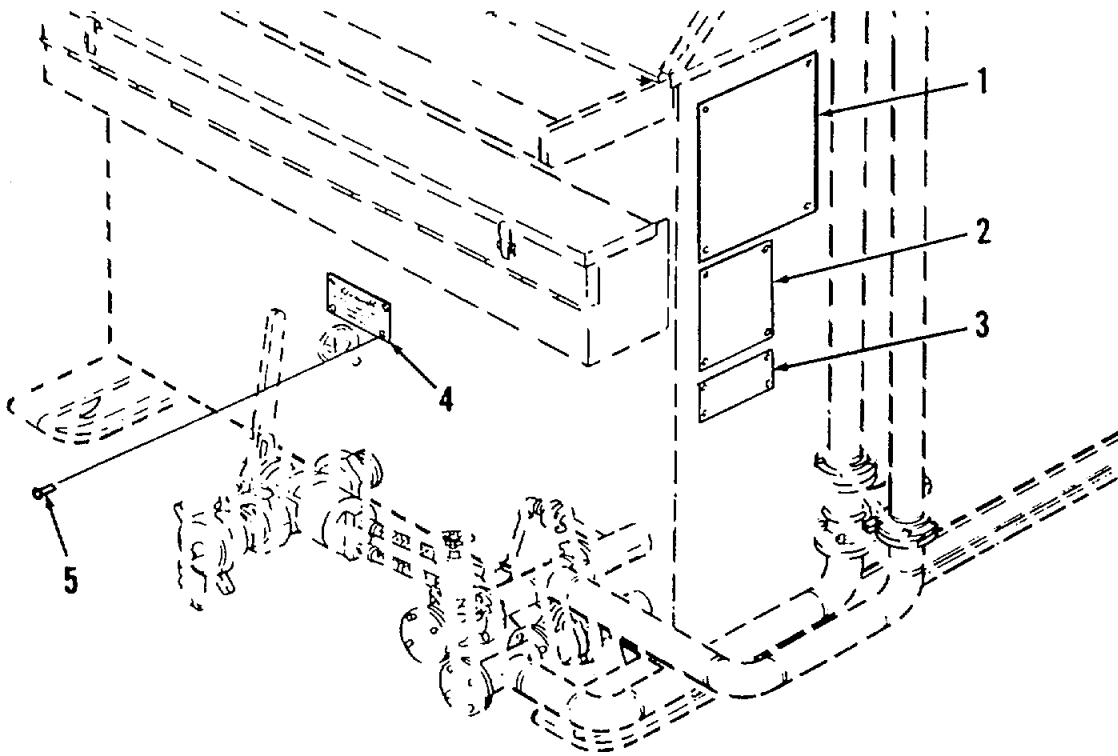

Figure 2. Plate/Decal Installation.

(1) ITEM NO	(2) SMR CODE	(3) CAGEC	(4) PART NUMBER	(5) DESCRIPTION AND USABLE ON CODES (UOC)	(6) QTY
-------------------	--------------------	--------------	-----------------------	--	------------

GROUP 2210 DATA PLATES

FIG. 2 PLATE/DECAL INSTALLATION

1	PAOZZ	11740	3000-109	PLATE, INSTRUCTION	1
2	PAOZZ	11740	3000-110	PLATE, INSTRUCTION	1
3	PAOZZ	11740	3000-111	PLATE, IDENTIFICATION	1
4	PAOZZ	11740	3000-112	PLATE, INSTRUCTION	1
5	PAOZZ	11740	MS21318-20	SCREW, DRIVE NO. 4 X 1/16 INCH LONG	16

END OF FIGURE

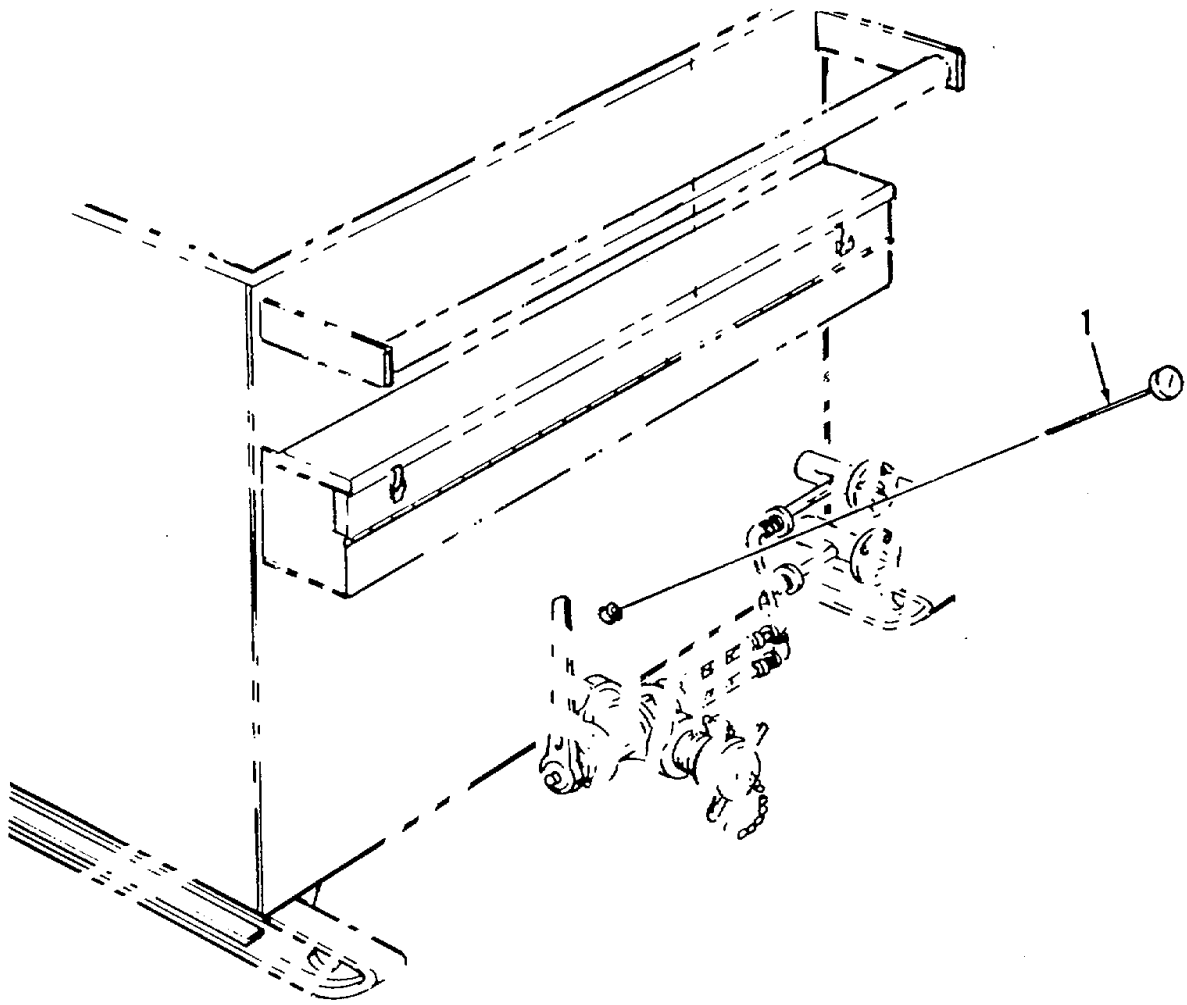

Figure 3. Thermometer.

SECTION II					
(1)	(2)	(3)	(4)	(5)	(6)
ITEM	SMR		PART	DESCRIPTION AND USABLE ON CODES (UOC)	
NO	CODE	CAGEC	NUMBER		QTY
				GROUP 47 GAUGES (NON-ELECTRICAL)	
				GROUP 4702 GAUGES, MOUNTING, LINES AND FITTINGS	
				FIG. 3 THERMOMETER	
1	PAOZZ	38056	30-EI-60R-240 50 /550DEG F	THERMOMETER, SELF-IN.	1

END OF FIGURE

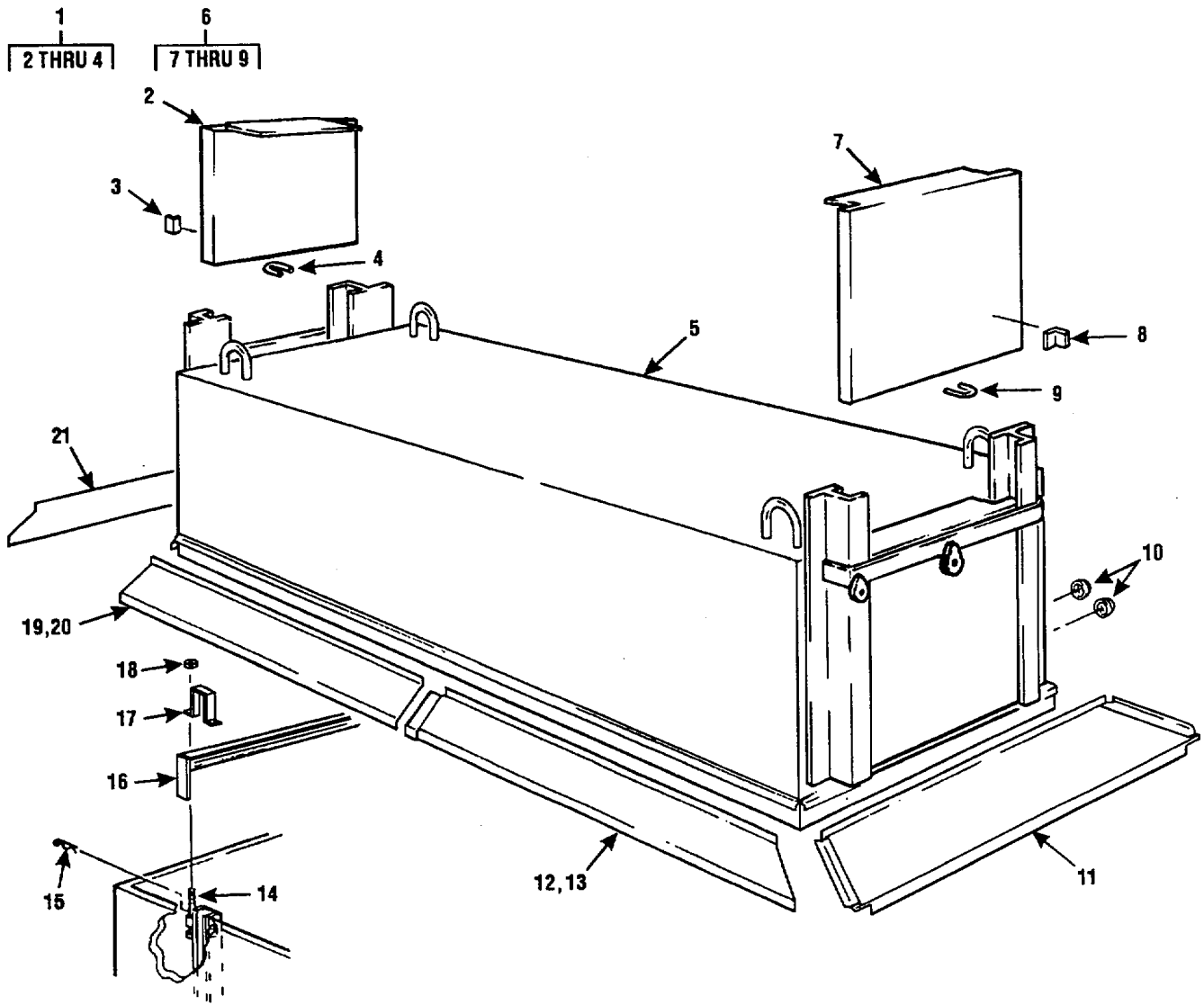

Figure 4. Dedrumming Tunnel and Guards.

SECTION II					
(1)	(2)	(3)	(4)	(5)	(6)
ITEM NO	SMR CODE	CAGEC	PART NUMBER	DESCRIPTION AND USABLE ON CODES (UOC)	QTY
GROUP 73 CONCRETE AND ASPHALT					
GROUP 7312 FEEDER OR CONVEYOR DISCHARGE					
FIG. 4 DEDRUMMING TUNNEL AND GUARDS					
1	AFFFF	11740	3000-139	DOOR ASSEMBLY, REAR	1
2	XBFZZ	11740	3000-139-1	DOOR, REAR.....	1
-3	XBFZZ	11740	3000-141	STOP, DOOR.....	2
4	XBFZZ	11740	3000-140	RING, DOOR LIFT	1
5	PFOFF	11740	3000-103	TUNNEL, ASPHALT MELT, INCLUDES.....	1
PULLEYS AS PART OF WELDMENT					
6	AFFFF	11740	3000-138	DOOR ASSEMBLY, FRT	1
7	XBFZZ	11740	3000-138-1	DOOR, FRONT	1
8	XBFZZ	11740	3000-141	STOP, DOOR,.....	2
9	XBFZZ	11740	3000-140	RING, DOOR LIFT	1
10	PAOZZ	14959	CAP-150-2	CAP, PIPE 2 INCH NPT.....	2
11	PFOZZ	11740	3000-12	CAP, PROTECTIVE, DUST	1
12	PFOZZ	11740	3000-13	RAINSHIELD, LH FORWARD	1
13	PFOZZ	11740	3000-14	RAINSHIELD, RH FORWARD.....	1
14	PAOZZ	11740	3000-24	CLAMP, BOLT.....	8
15	PFOZZ	11740	ST-M-C-7	PIN, LOCK.....	8
16	PAOZZ	11740	3000-25	FRAME, STRUCTURAL, VE.....	2
17	PAOZZ	11740	3000-23	BAR, HOLD DOWN	4
18	PFOZZ	96906	MS51967-14	NUT, PLAIN, HEXAGON 1/2UNC-2B	8
19	PFOZZ	11740	3000-15	RAINSHIELD, LH REAR	1
20	PFOZZ	11740	3000-16	RAINSHIELD, RH REAR.....	1
21	PFOZZ	11740	3000-17	RAINSHIELD.....	1

END OF FIGURE

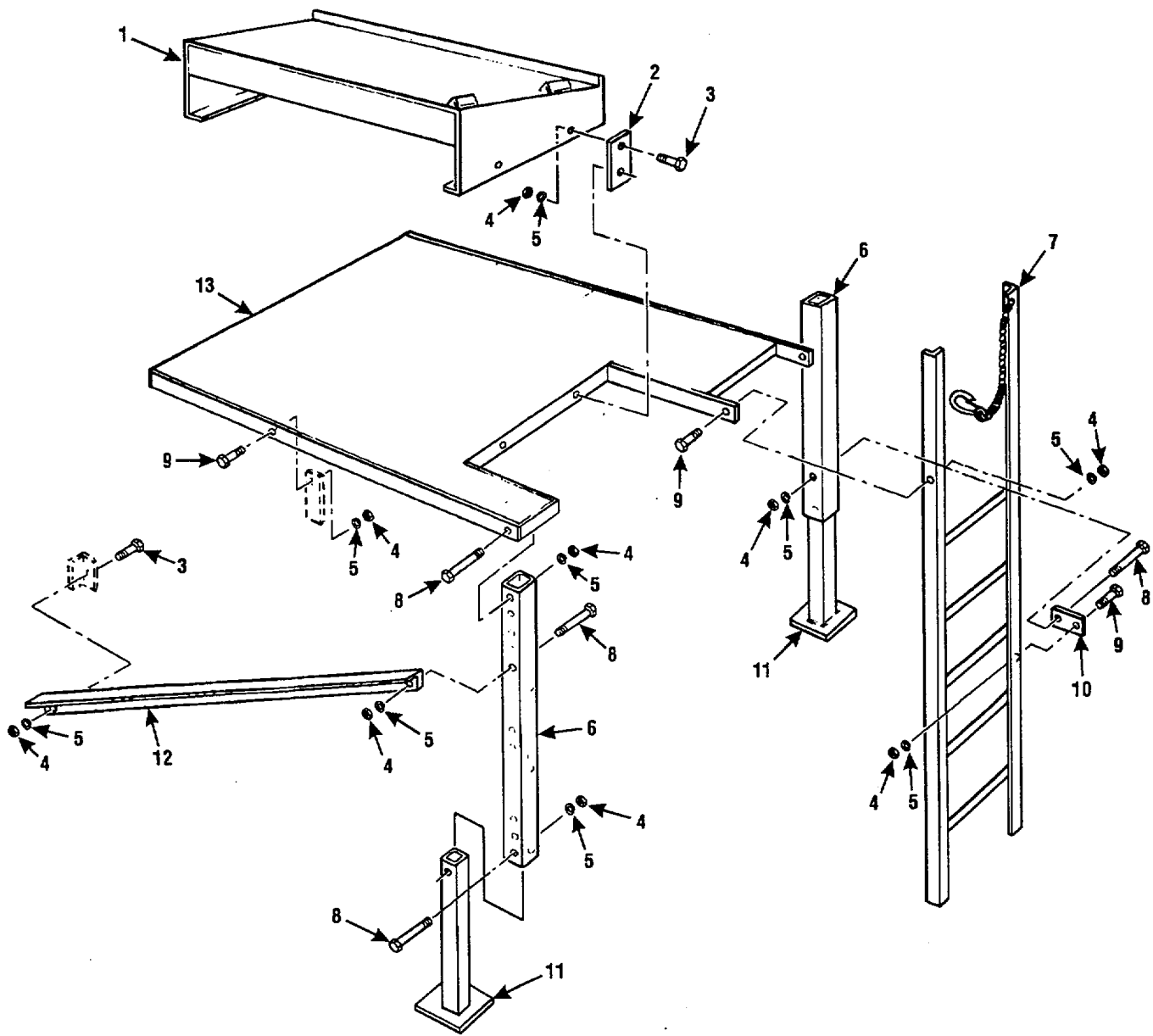

Figure 5. Loading Platform.

SECTION II					
(1)	(2)	(3)	(4)	(5)	(6)
ITEM NO	SMR CODE	CAGEC	PART NUMBER	DESCRIPTION AND USABLE ON CODES (UOC)	QTY
GROUP 7312 FEEDER OR CONVEYOR DISCHARGE					
FIG. 5 LOADING PLATFORM					
1	XBOZZ	11740	3000-128	RAMP, LOAD	1
2	XBOZZ	11740	3000-129	BRACKET, LOAD RAMP	2
3	PAOZZ	80204	B1821BHO38 C100N	SCREW, CAP, HEXAGON H 3/8-16NC X 1	6
4	PAOZZ	96906	MS51967-8	NUT, PLAIN, HEXAGON 3/8-16NC	18
5	PAOZZ	81718	H2525M	WASHER, LOCK 3/8 INCH SPLIT	18
6	XBOZZ	11740	3000-132	LEG, PLATFORM	2
7	XBOZZ	11740	3000-126	LADDER, INCLUDES CHAIN AND HOOK	1
AS WELDMENT					
8	PAOZZ	B0204	B1821BH038C300N	SCREW, CAP, HEXAGON H 3/8-16NC X 3	7
INCHES.....					
9	PAOZZ	80204	B1821BH038C150N	SCREW, CAP, HEXAGON H 3/8-16NC X 1 1/	5
2 INCHES.....					
10	XBOZZ	11740	3000-127	BRACE, LADDER.	1
11	XBOZZ	11740	3000-133	LEG EXTENSION, PLAT	2
12	XBOZZ	11740	3000-131	BRACE, PLATFORM	2
13	XBOZZ	11740	3000-130	PLATFORM, LOAD	1

END OF FIGURE

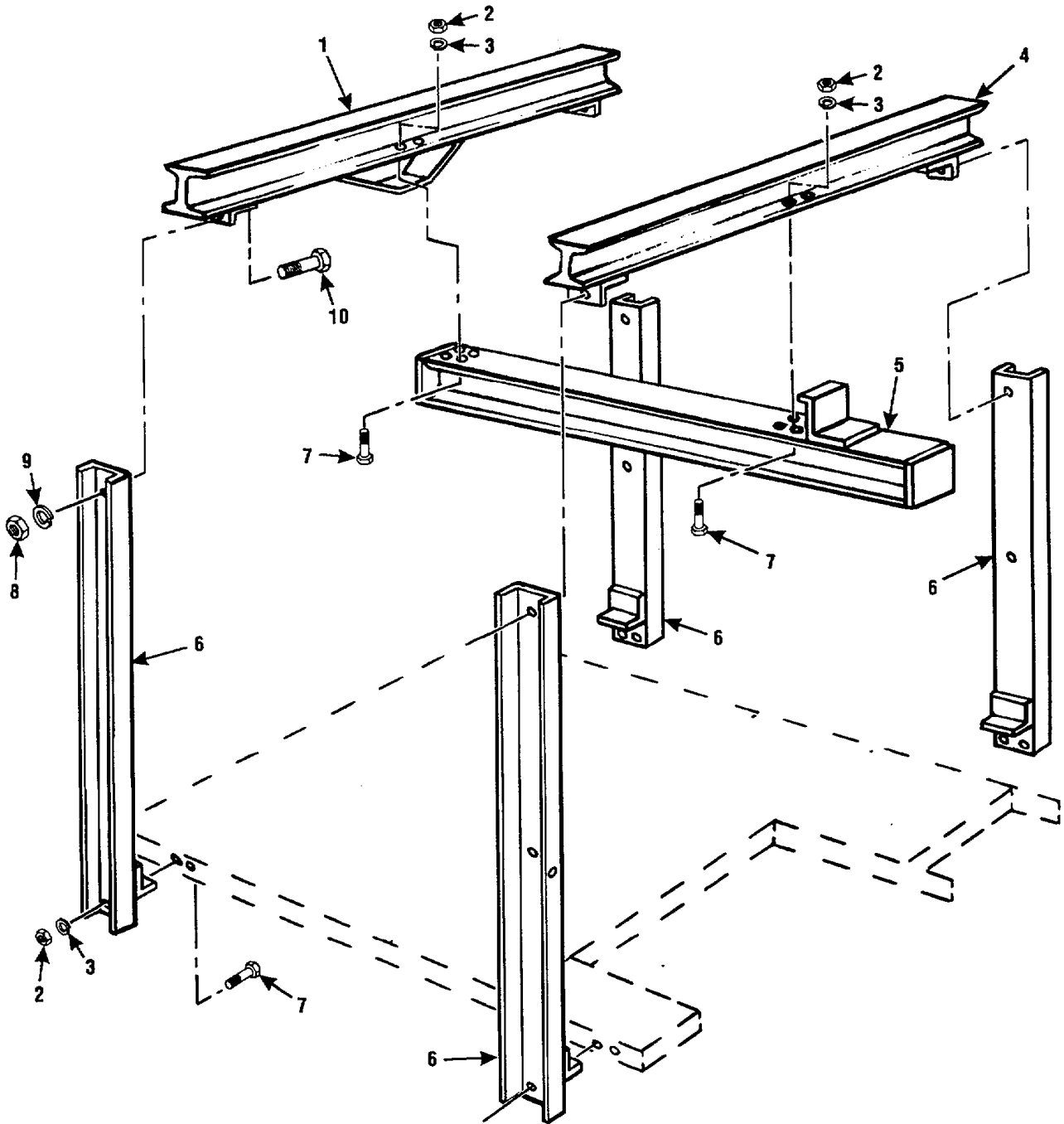

Figure 6. Upper Structure, Loading Platform.

SECTION II					
(1)	(2)	(3)	(4)	(5)	(6)
ITEM NO	SMR CODE	CAGEC	PART NUMBER	DESCRIPTION AND USABLE ON CODES (UOC)	QTY
				GROUP 7312 FEEDER OR CONVEYOR DISCHARGE	
				FIG. 6 UPPER STRUCTURE, LOADING PLATFORM	
1	XBOZZ	11740	3000-115	CROSS BEAM, REAR	1
2	PAOZZ	96906	MS51967-8	NUT, PLAIN, HEXAGON 3/d-16NC	16
3	PAOZZ	81718	H2525M	WASHER, LOCK 3/8 INCH SPLIT	16
4	XBOZZ	11740	3000-114	CROSS BEAM, FRONT	1
5	XBOZZ	11740	3000-116	RAIL, TROLLEY	1
6	XBOZZ	11740	3000-113	SUPPORT, UP-RIGHT	4
7	PAOZZ	80204	B1821BH038C150N	SCREW, CAP, HEXAGON H 3/8-16NC X 1 1/2 INCHES.....	16
8	PAOZZ	96906	MS51967-20	NUT, PLAIN, HEXAGON 5/8-11NC	4
9	PAOZZ	96906	MS51415-10	WASHER, LOCK 5/8 INCH.....	4
10	PAOZZ	30204	81821BH063C150N	SCREW, CAP, HEXAGON H 5/8-11NC X 1 1/2 INCHES.....	4

END OF FIGURE

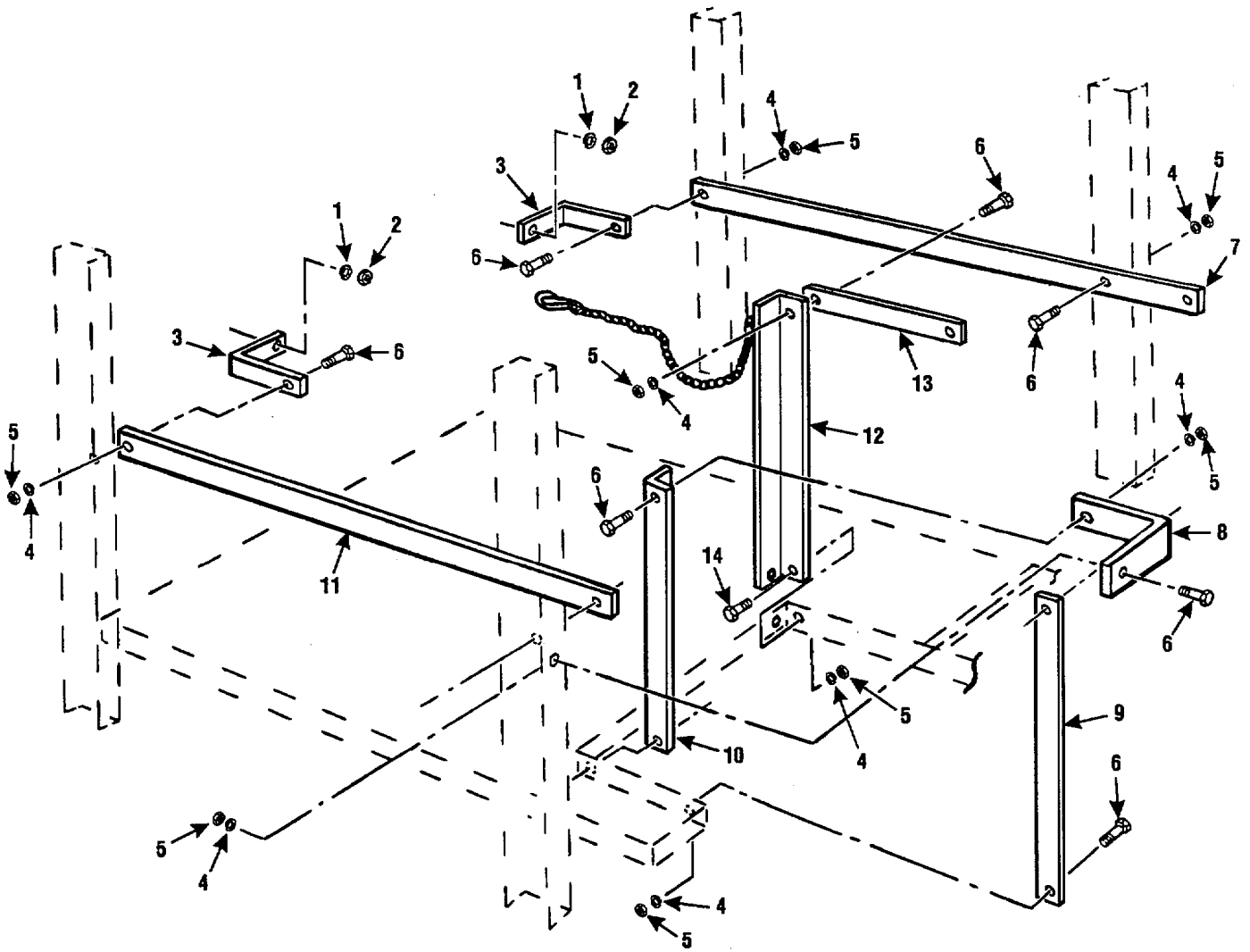

Figure 7. Guard Rails.

SECTION II					
(1)	(2)	(3)	(4)	(5)	(6)
ITEM NO	SMR CODE	CAGEC	PART NUMBER	DESCRIPTION AND USABLE ON CODES (UOC)	QTY
GROUP 7312 FEEDER OR CONVEYOR DISCHARGE					
FIG. 7 GUARD RAILS					
1	PAOZZ	96906	MS51415-7	WASHER, LOCK 1/2 INCH SPLIT	2
2	PAOZZ	96906	MS51967-14	NUT, PLAIN, HEXAGON 3/8-16NC	2
3	XBOZZ	11740	3000-118	RAILING, RR CORNER	2
4	PAOZZ	81718	H2525M	WASHER, LOCK 3/8 INCH SPLIT	13
5	PAOZZ	96906	MS51967-8	NUT, PLAIN, HEXAGON 3/8-16NC	13
6	PAOZZ	80204	B1821BH038C150N	SCREW, CAP, HEXAGON H 3/8-16NC X 1 1/2 INCHES.....	9
7	XBOZZ	11740	3000-120	RAILING, LEFT SIDE	1
8	XBOZZ	11740	3000-122	RAILING, FRT CORNER	1
9	XBOZZ	11740	3000-123	SUPPORT, FRT RAIL	1
10	XBOZZ	11740	3000-124	SUPPORT, RT RAIL	1
11	XBOZZ	11740	3000-119	RAILING, RT SIDE	1
12	XBOZZ	11740	3000-125	SUPPORT, LT RAIL, INCLUDES CHAIN AND HOOK AS WELDMENT	1
13	XBOZZ	11740	3000-121	RAILING, LADDER	1
14	PAOZZ	80204	81821BH038C100N	SCREW, CAP, HEXAGON H 3/8-16NC X 1 INCH.....	4

END OF FIGURE

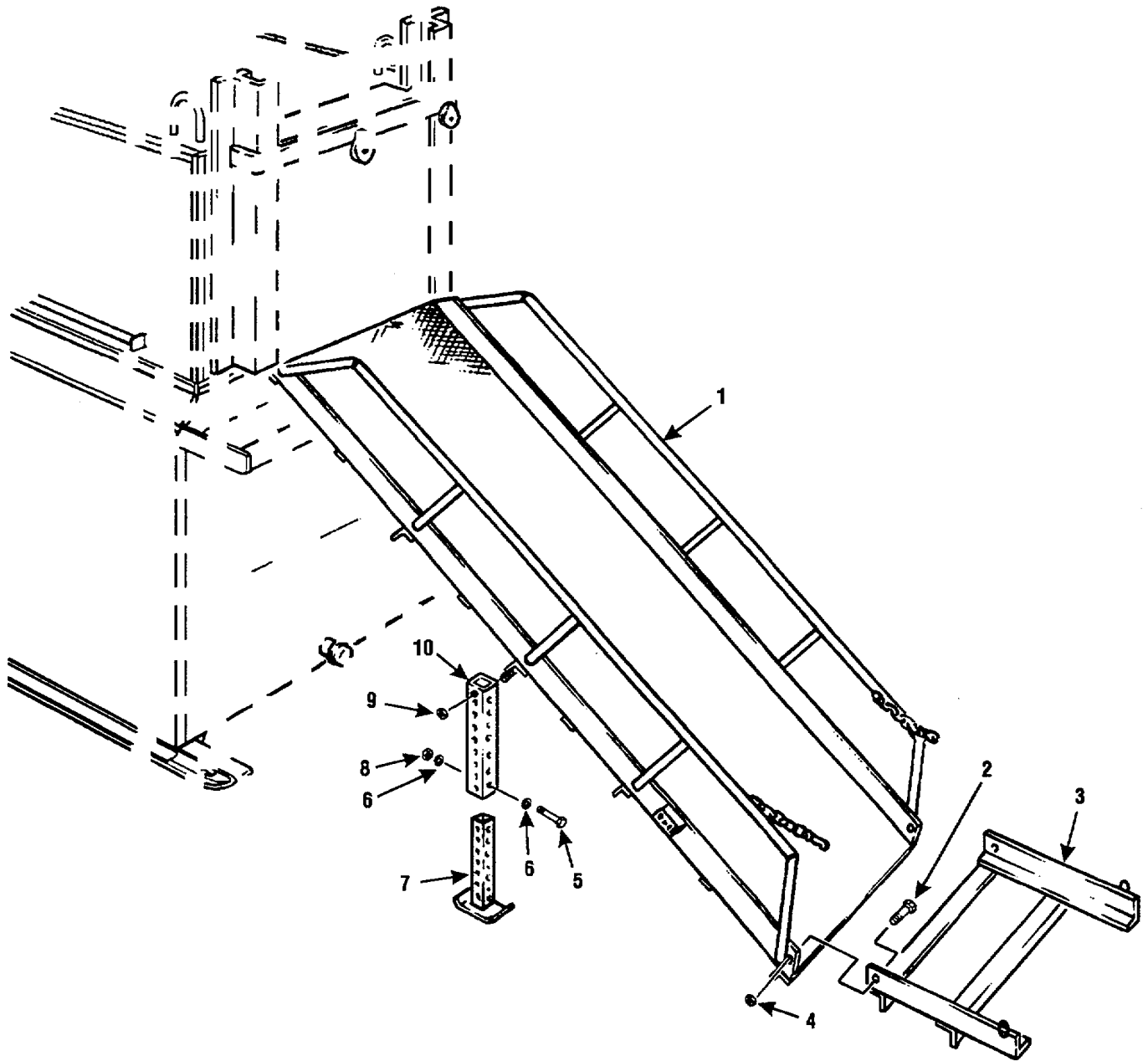

Figure 8. Discharge Chute.

SECTION II					
(1)	(2)	(3)	(4)	(5)	(6)
ITEM NO	SMR CODE	CAGEC	PART NUMBER	DESCRIPTION AND USABLE ON CODES (UOC)	QTY
				GROUP 7312 FEEDER OR CONVEYOR DISCHARGE	
				FIG. 8 DISCHARGE CHUTE	
1	XBOZZ	11740	3000-136	CHUTE, DISCHARGE, INCLUDES CHAINS..... AND HOOKS AS WELDMENT	1
2	PAOZZ	80204	B1821BH038C150N	SCREW, CAP, HEXAGON H 3/8-16NC X 1 1/..... 2 INCHES.....	2
3	XBOZZ	11740	3000-137	RETAINER, BARREL.....	1
4	PAOZZ	96906	MS51922-18	NUT, SELF-LOCKING, HE 3/8-156NCC	2
5	PAOZZ	80204	81821BH038C250N	SCREW, CAP, HEXAGON H 3/8-16NC X 2 1/..... 2 INCHES.....	2
6	PADZZ	96906	M527183-14	WASHER, FLAT 3/16 INCH.....	4
7	XBOZZ	11740	3000-135	LEG EXTENSION, CHUT	2
8	PAOZZ	96906	MS51967-3	NUT, PLAIN, HEXAGON 3/8-16NC	2
9	PAOZZ	96906	MS51922-33	NUT, SELF-LOCKING, HE 1/2-13UNC-2B.....	2
10	XBOZZ	11740	3000-134	LEG, CHUTE.....	2

END OF FIGURE

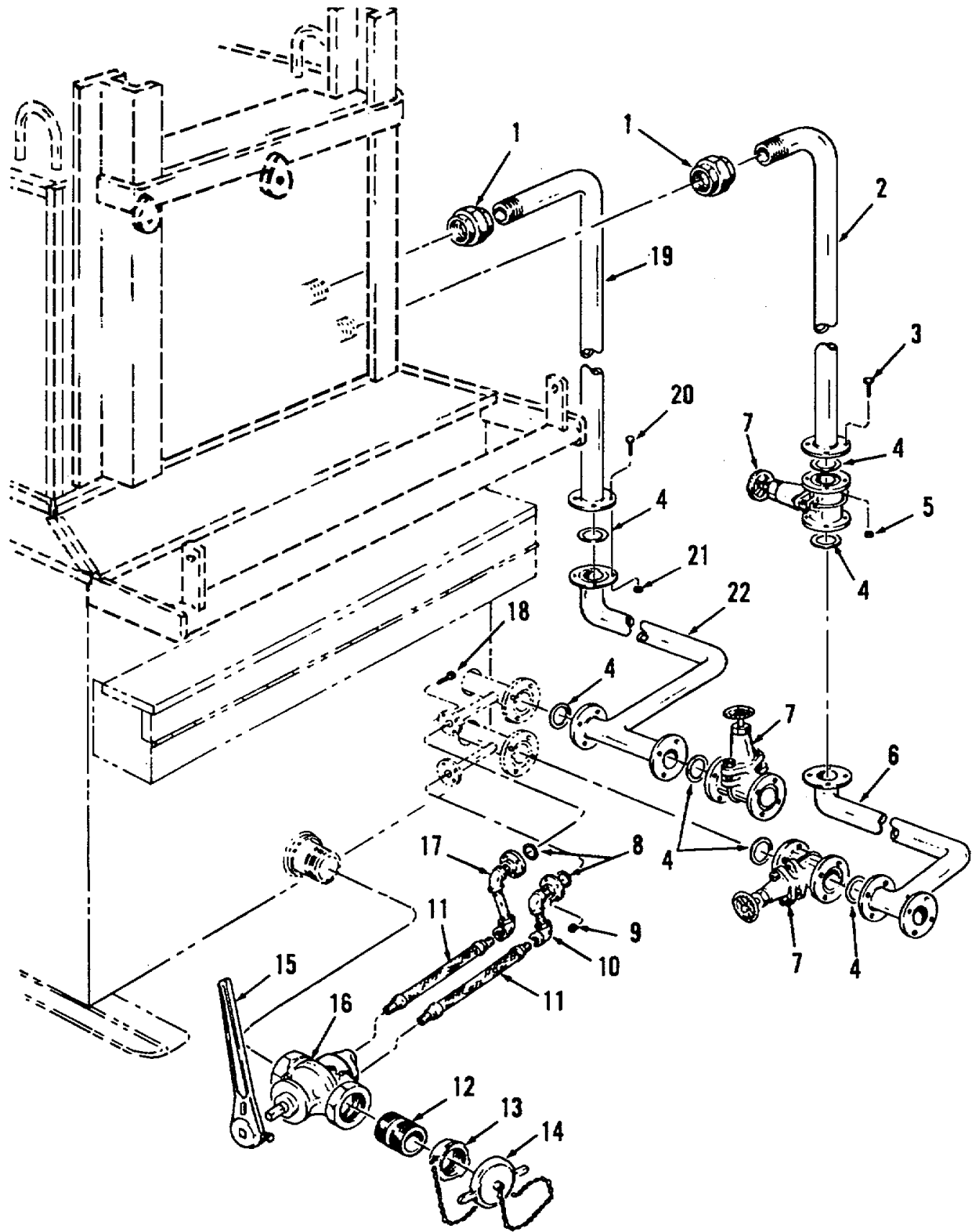

Figure 9. Valves and Hot Oil Piping.

SECTION II					
(1)	(2)	(3)	(4)	(5)	(6)
ITEM NO	SMR CODE	CAGEC	PART NUMBER	DESCRIPTION AND USABLE ON CODES (UOC)	QTY
GROUP 7318 TANKS, VALVES, FORMED HOSES, LINES, FITTINGS					
FIG. 9 VALVES AND HOT OIL PIPING					
1	PAOZZ	88772	115T304SS-2	UNION, PIPE 2 INCH NPT, STAINLESS..... STEEL SEAT.....	2
2	PAOZZ	11740	3000-5	PIPE ASSEMBLY, METAL.....	1
3	PFOZZ	30204	B1821BH063C200N	SCREW, CAP, HEXAGON H 5/8-11UNC-2A X..... 2 INCH LONG, GRADE 5	24
4	PAOZZ	11740	3000-6	GASKET 2 INCH RING.....	7
5	PFOZZ	96906	MS51967-20	NUT, PLAIN, HEXAGON 5/8-11UNC-ZB.....	24
6	PAOZZ	11740	3000-4	PIPE ASSEMBLY, METAL.....	1
7	PAOZZ	14959	488-1/2-2	VALVE, GATE 2 INCH FLANGED	3
8	PAOZZ	11740	3000-3	GASKET 3/4 INCH RING.....	2
9	PFOZZ	96906	MS51967-14	NUT, PLAIN, HEXAGON 1/2-13UNC-2B.....	8
10	PAOZZ	11740	3000-1	PIPE ASSEMBLY, METAL.....	1
11	PAOZZ	16327	4Z067	HOSE ASSEMBLY, METAL.....	2
12	PAOZZ	96906	MS51953-241	NIPPLE, PIPE 3 INCH NPT X 3 INCH	1
13	PAOZZ	41592	2951-4	COUPLING, HOSE 3 INCH	1
14	PAOZZ	41592	27755	CAP, PROTECTIVE, DUST, INCLUDES..... CHAIN WITH ATTACHING PARTS	1
15	PFOZZ	29215	L	HANDLE, MANUAL CONTR	1
16	PAOZZ	29215	601-SJ-3	VALVE, PLUG 3 INCH WITH 3/4NPT	1
17	PAOZZ	11740	3000-2	PIPE ASSEMBLY, METAL.....	1
18	PFOZZ	80204	B121BH050C200N	SCREW, CAP, HEXAGON H 1/2-13UNC-2A X..... 2 INCH LONG, GRADE 5	8
19	PAOZZ	11740	3000-8	PIPE ASSEMBLY, METAL.....	1
20	PFOZZ	80204	31821BH063C250N	SCREW, CAP, HEXAGON H 5/8-11UNC-2A X..... 2.5 INCH LONG, GRADE 5	3
21	PFOZZ	96906	MS51967-20	NUT, PLAIN, HEXAGON 5/8-11UNC-2B.....	8
22	PAOZZ	11740	3000-7	PIPE ASSEMBLY, METAL.....	1

END OF FIGURE

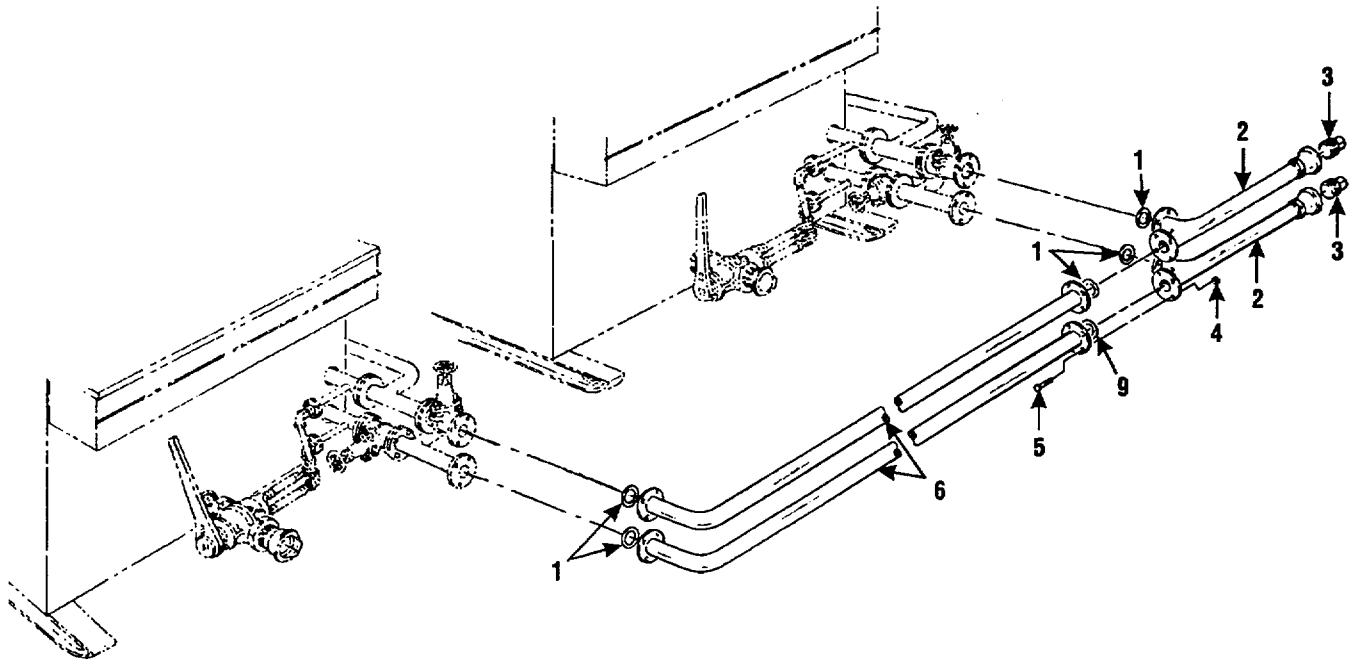

Figure 10. Connecting Hot Oil Piping.

(1) ITEM NO	(2) SMR CODE	(3) CAGEC	(4) PART NUMBER	(5) DESCRIPTION AND USABLE ON CODES (UOC)	(6) QTY
-------------------	--------------------	--------------	-----------------------	--	------------

GROUP 7318 TANKS, VALVES, FORMED
HOSES, LINES, FITTINGS

FIG. 10 CONNECTING HOT OIL PIPING

1	PAOZZ	11740	3000-6	GASKET 2 INCH RING.....	4
2	PAOZZ	11740	3000-10	PIPE ASSEMBLY, METAL	2
3	XBOZZ	96906	MS51884-19	PLUG, PIPE 2.5 INCH NPT, SQUARE HEAD	2
4	PFOZZ	96906	MS51967-20	NUT, PLAIN, HEXAGON 5/6-11UNC-28	16
5	PFOZZ	80204	B1821BH063C250N	SCREW, CAP, HEXAGON H 5/8-11UNC-2A X.....	16
6	PFOZZ	11740	3000-11	2.5 INCH LONG, GRADE 5	
				PIPE ASSEMBLY, METAL.....	1

END OF FIGURE

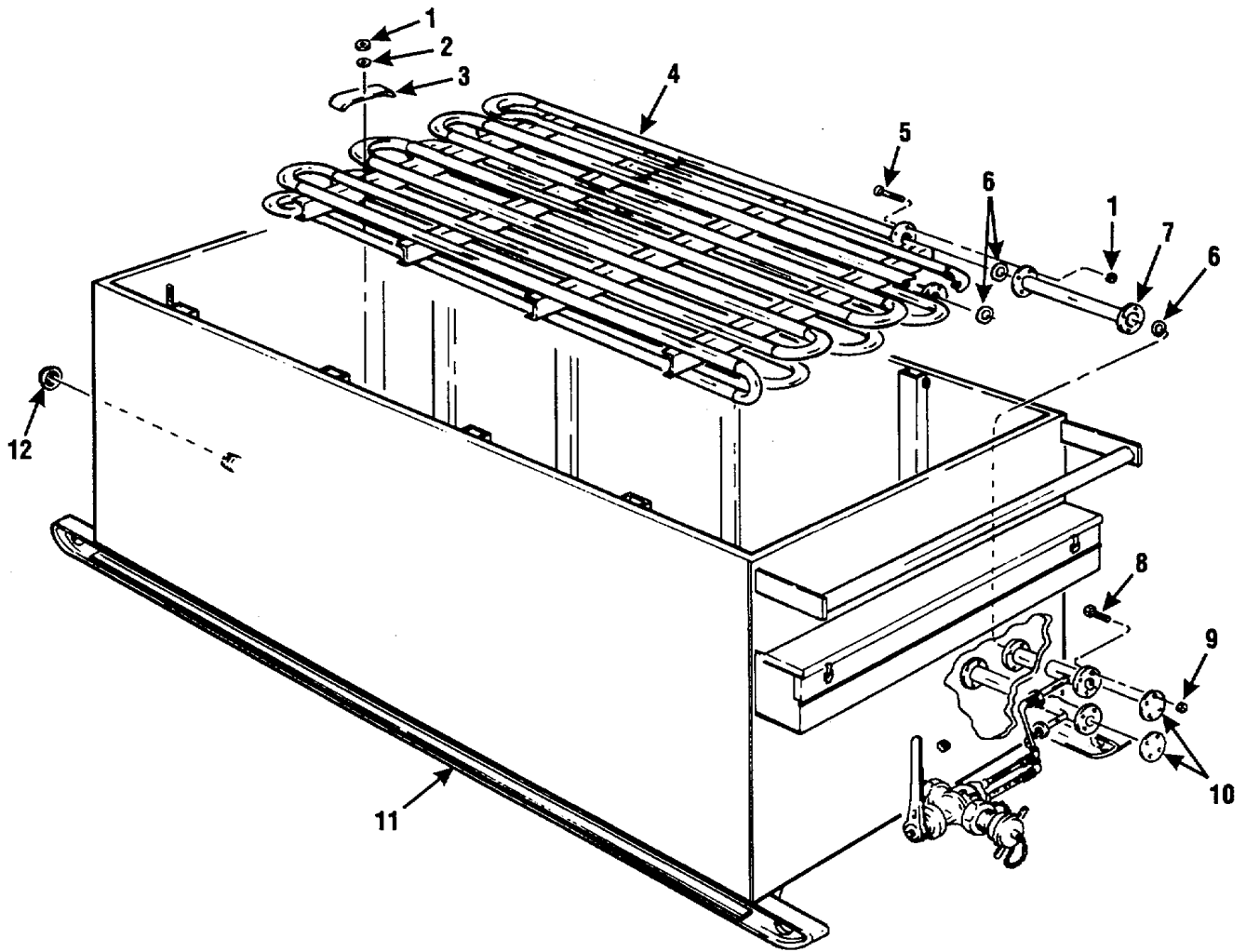

Figure 11. Storage Tank and Pipe Coils.

SECTION II					
(1)	(2)	(3)	(4)	(5)	(6)
ITEM NO	SMR CODE	CAGEC	PART NUMBER	DESCRIPTION AND USABLE ON CODES (UOC)	QTY
				GROUP 7318 TANKS, VALVES, FORMED HOSES, LINES, FITTINGS	
				FIG. 11 STORAGE TANK AND PIPE COILS	
1	PFFZZ	96906	MS51967-20	NUT, PLAIN, HEXAGON 5/8-11UNC-2R.....	15
2	PFFZZ	96906	MS27183-21	WASHER, FLAT 5/8 INCH.....	4
3	PFFZZ	11740	3000-27	CLAMP, BRIDGE	4
4	PAFHH	11740	3000-28	HEATER, BITUMEN	1
5	PFFZZ	80204	B1821BH063C250N	SCREW, CAP, HEXAGON H 5/8-11UNC-ZA X 2.5 INCH LONG, GRADE 5	12
6	PAFZZ	11740	3000-6	GASKET 2 INCH RING.....	3
7	PAFZZ	11740	3000-26	PIPE ASSEMBLY, METAL.....	1
8	PAOZZ	80204	B1821BH063C250N	SCREW, CAP, HEXAGON H 5/8-11UNC-2A X d 2.5 INCH LONG, GRADE 5,	
9	PAOZZ	96906	MS51967-20	NUT, PLAIN, HEXAGON 5/8-11UNC-ZB.....	8
10	PFOZZ	14959	555-2	FLANGE, PIPE, BLIND	2
11	PFOZZ	11740	3000-I04	TANK, ASPHALT STORAGE.....	1
12	PAOZZ	14959	CAP-150-2	CAP, PIPE.....	1

END OF FIGURE

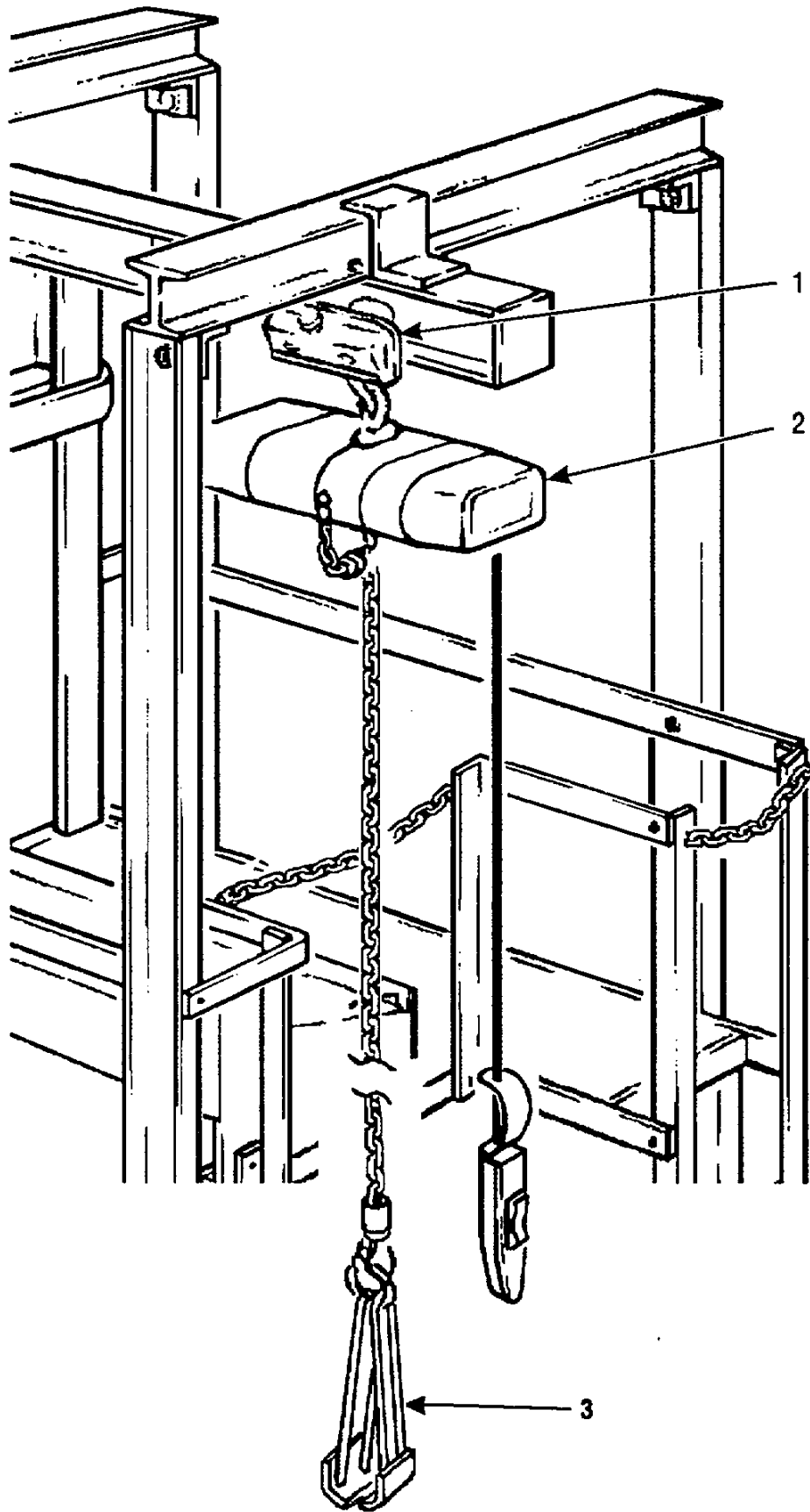

Figure 12. Electric Hoist Installation.

SECTION II					
(1)	(2)	(3)	(4)	(5)	(6)
ITEM	SMR		PART		
NO	CODE	CAGEC	NUMBER	DESCRIPTION AND USABLE ON CODES (UOC)	QTY
GROUP 7320 BOOM AND ATTACHING PARTS					
FIG. 12 ELECTRIC HOIST INSTALLATION					
1	XBOOO	12128	3222	TROLLEY, I-BEAM.....	1
2	XBOFF	12128	2403	HOIST ASSEMBLY.....	1
3	PAOZZ	45861	MODEL41DRUM SLING	SLING, DRUM LIFTING.....	1

END OF FIGURE

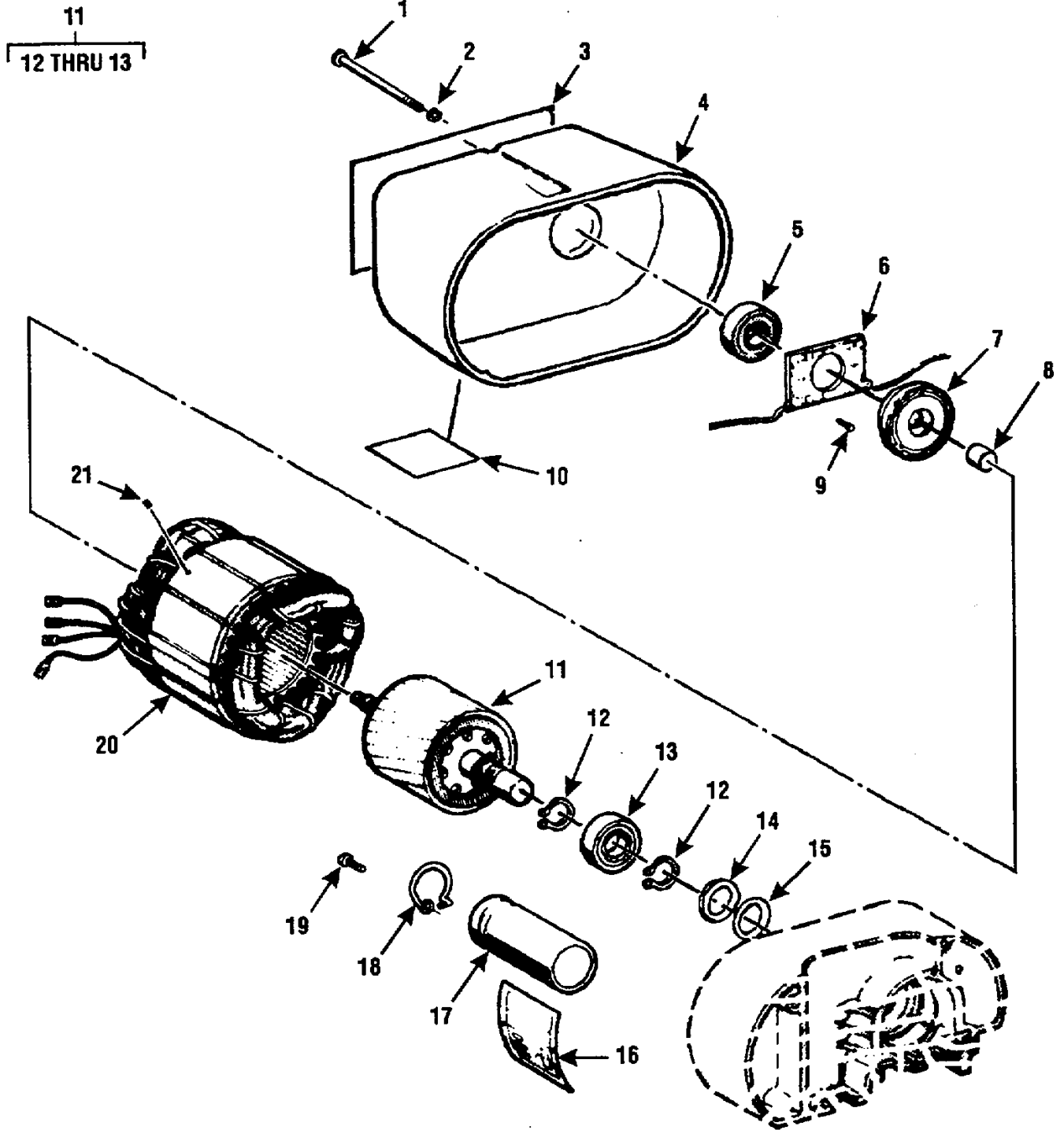

Figure 13. Electric Hoist, Motor End

SECTION II					
(1)	(2)	(3)	(4)	(5)	(6)
ITEM NO	SMR CODE	CAGEC	PART NUMBER	DESCRIPTION AND USABLE ON CODES (UOC)	QTY
GROUP 7320 BOOM AND ATTACHING PARTS					
FIG. 13 ELECTRIC HOIST, MOTOR END					
1	KFFZZ	12128	940822	SCREW, MACH, FIL HO 1/4-20NC X 1 1/2.....	2
2	KFFZZ	12128	940802	2 INCHES PART OF KIT P/N C302.....	2
3	XBFZZ	12128	24707	WASHER, LOCK 1/4 INCH PART OF KIT P/N C302.....	1
4	XBFZZ	12128	24504	LABEL, PRODUCT.....	1
5	XBFZZ	12128	82001	COVER, MOTOR HSG.....	1
6	KFFZZ	12128	2472w	BEARING, BALL, ANNULA.....	1
7	KFFZZ	12128	24753	SWITCH, STATIONARY PART OF KIT P/N C337.....	1
8	KFFZZ	12128	24360	CENTRIFUGAL MECHAN PART OF KIT P/N C349.....	1
9	KFFZZ	12128	987523	SPACER PART OF KIT P/N C349.....	2
10	XBFZZ	12128	24842	SCREW, MACH, RD HO NO. B-32NC X 1/2 PART OF KIT P/N C337.....	1
11	XBFFF	12124	24633	DECAL, WARNING.....	1
12	XBFZZ	12128	27790	ROTOR ASSEMBLY.....	2
13	XBFZZ	12128	82003	RING, RETAINING.....	1
14	XBFZZ	12128	27292	BEARING, INBOARD.....	1
15	XBFZZ	12128	27291	WASHER, WAVE.....	1
16	XBFZZ	12128	24770	SPACER.....	1
17	XBFZZ	12128	27716	LABEL, IDENTIFICAT.....	1
18	KFFZZ	12128	27753	CAPACITOR.....	1
19	KFFZZ	12128	982688	SPRING, MOUNTING PART OF KIT P/N C336.....	1
20	XBFZZ	12128	24720	SCREW, MACH, FIL HD 1/4-20NC X 1/2 PART OF KIT P/N C336.....	1
21	XBFZZ	12128	983541	STATOR ASSEMBLY.....	1
				PIN, STATOR.....	1

END OF FIGURE

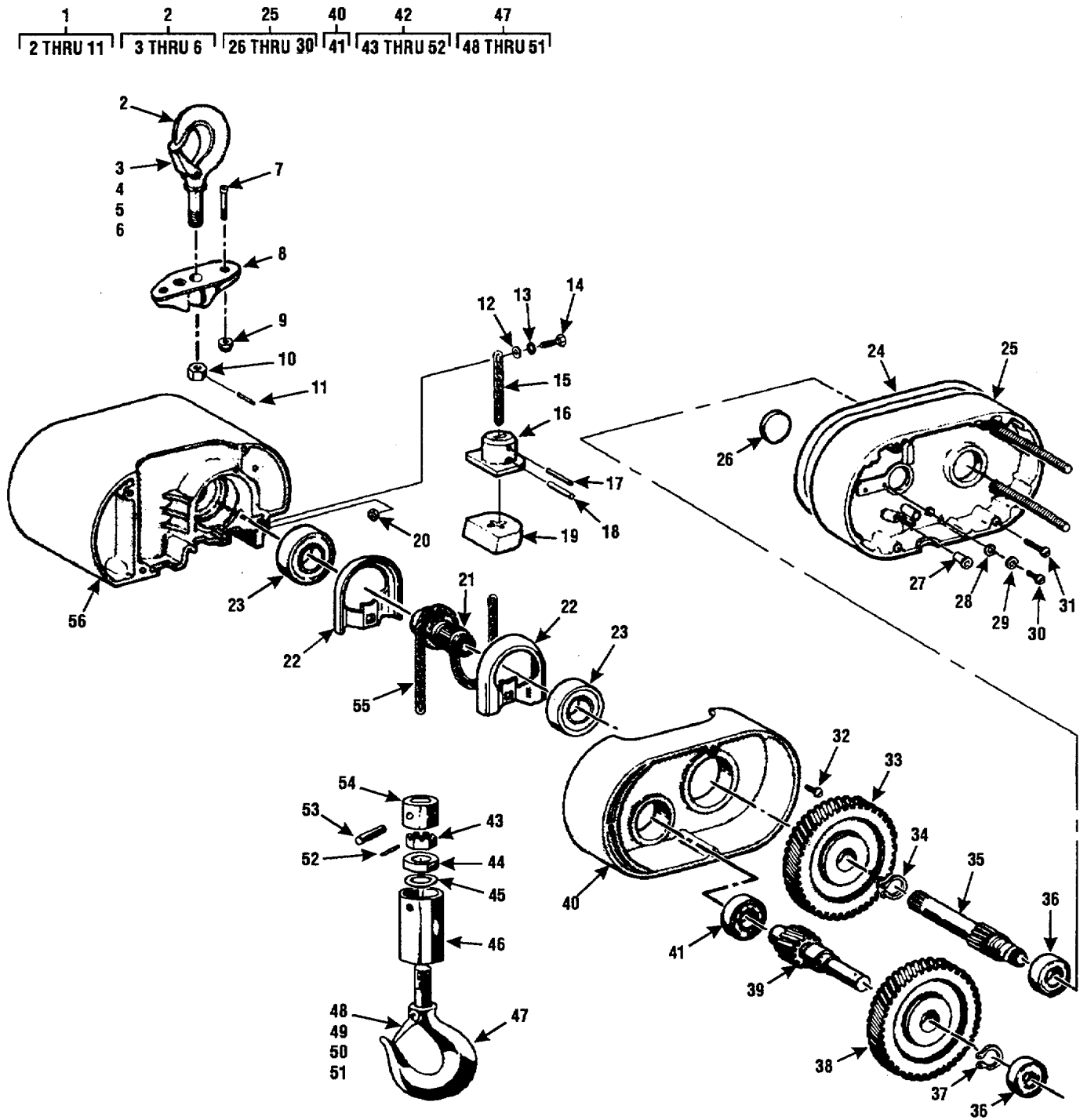

Figure 14. Electric Hoist, Gears and Hooks.

(1) ITEM NO	(2) SMR CODE	(3) CAGEC	(4) PART NUMBER	(5) DESCRIPTION AND USABLE ON CODES (UOC)	(6) QTY
GROUP 7320 BOOM AND ATTACHING PARTS					
FIG. 14 ELECTRIC HOIST SEARS AND HOOKS					
1	XBFFF	12128	2788	HOOK ASSY, SUSPENSI.....	1
2	KBFFF	12128	28689	HOOK ASSEMBLY	1
3	KFOZZ	12128	82280	LATCH, SAFETY PART OF KIT P/N	1
				45661	
4	KFOZZ	12123	937448	SCREW, MACH, RD HD NO. 5-40NC X	1
				1 ¼ INCHES PART OF KIT P/N 45661	
5	KFOZZ	12128	86171	SPRINGER, LATCH PART OF KIT P/N	1
				45661	
6	KFOZZ	12128	982627	NUT, SELF LOCKING NO. 5-40NC PART	1
				OF KIT P/N 45661.....	
7	XBFZZ	12128	987554	SCREW, MACH RD HD 3/8-16NC X 1 1/.....	2
				2 INCHES.....	
3	XBFZZ	12128	27703	ADAPTER, SUSPENSION.....	1
9	XBFZZ	12128	927755	NUT, PLAIN HEX	2
10	KFFZZ	12128	27361	COLLAR PART OF KIT P/N C329	1
11	KFFZZ	12128	27805	PIN PART OF KIT P/N C329	1
12	KFFZZ	12128	954802	WASHER, FLAT ¼ INCH PART OF KIT	1
				P/N C304.....	
13	KFFZZ	12128	982226	WASHER, LOCK ¼ INCH PART OF KIT	1
				P/N C3304.....	
14	KFFZZ	12126	927764	SCREW, CAP, HEX HO 1/4-20NC X 1.....	1
				INCH PART OF KIT P/N C3040.....	
15	XBFZZ	12128	85832	CHAIN, LOOSE END	1
16	XBFZZ	12128	24015	BLOCK, LOOSE END	1
17	KFFZZ	12128	983764	PIN PART OF KIT P/N C328., ,	1
18	KFOZZ	12128	924787	PIN, GROOVED PART OF KIT P/N C32.....	1
19	XBOZZ	12128	24785	BLOCK, STOP,	1
20	XBFZZ	12128	82638	NUT, LOOSE END.....	1
21	XBFZZ	12128	27360	LIFTWHEEL	1
22	XBFZZ	12128	27008	GUIDE, CHAIN.....	2
23	XBFZZ	12128	88429	BEARING, BALL, ANNULA.....	2
24	XBFZZ	12128	27747	GASKET, HOUSING	1
25	XBFZZ	12128	24620	FRAME ASSEMBLY	1
26	XBFZZ	12123	940337	PLUG, EXPANSION.....	1
27	XBFZZ	12128	982454	PLUG.....	4
28	KFFZZ	12128	982106	WASHER, FLAT NO. 6 PART OF KIT P/N	1
				C307307.....	
29	KFFZZ	12125	9R6285	WASHER, LOCK NO. 6 INTERNAL TOOTH	1
				PART OF KIT P/N C3071	
30	KFFZZ	12128	987519	.SCREW, SELFTAP RH NO 6-32NC X 3/.....	1
				8 INCH, TYPE F PART OF KIT P/N C307.....	
31	XBFZZ	12128	982699	SCREW, MACH RD H D.....	3
32	XBFZZ	12128	28830	SCREW, CAP	4
33	XBFZZ	12128	27009	GEAR, LIFTWHEEL.....	1
34	XBFZZ	12128	27767	RING, RETAINING.....	1
35	XBFZZ	12128	24642	SHAFT & PINION ASSY	1
36	XBFZZ	12128	32001	BEARING, BALL, ANNULA.....	2

SECTION II					
(1)	(2)	(3)	(4)	(5)	(6)
ITEM	SMR		PART	DESCRIPTION AND USABLE ON CODES (UOC)	QTY
NO	CODE	CAGEC	NUMBER		
37	XBFZZ	12128	27765	RING, RETAINING.....	1
31	XBFZZ	12128	28695	PROTECTOR, ,.....	1
39	XBFZZ	12128	24351	PINION, INTERMEDIAT	1
40	XBFZZ	12128	28669	HOUSING, GEAR	1
41	XBFZZ	12128	88440	BEARING, INBOARD.....	1
42	XBOZZ	12126	28679	HOOK & BLOCK ASSY.....	1
43	XBOZZ	12128	982526	NUT, SLOTTED	1
44	XBOZZ	12128	88485	BEARING, ROLLER, THRU.....	1
45	XBOZZ	12128	945921	BEARING, WASHER, THRU	1
46	XBOZZ	12128	45401	BODY, LOWER HOOK	1
47	XBOOO	12128	2886	HOOK ASSEMBLY, LOWE.....	1
48	KFOZZ	12128	82280	LATCH, SAFETY PART OF KIT P/N	1
				45661	
49	KFOZZ	12128	987448	SCREW, MACH, RD HD NO 5-40NC X	2
				1 ¼ INCHES PART OF KIT P/N 45661	
50	KFOZZ	12128	86171	SPRING, LATCH PART OF KIT P/N	1
				45661	
51	KFOZZ	12128	982627	NUT, SELF LOCKING NO. 5-40NC PART	2
				OF KIT P/N 45661. 61.....	
52	XBOZZ	12128	983772	PIN, STRAIGHT, HEADLE.....	1
53	XBOZZ	12128	45943	PIN, STRAIGHT, HEADLE.....	1
54	XBOZZ	12128	28007	COLLAR, SHAFT	1
55	XBOZZ	12128	35944-10.5	CHAIN, LOAD	1
56	XBFZZ	12128	27028	HOUSING, MOTOR	1

END OF FIGURE

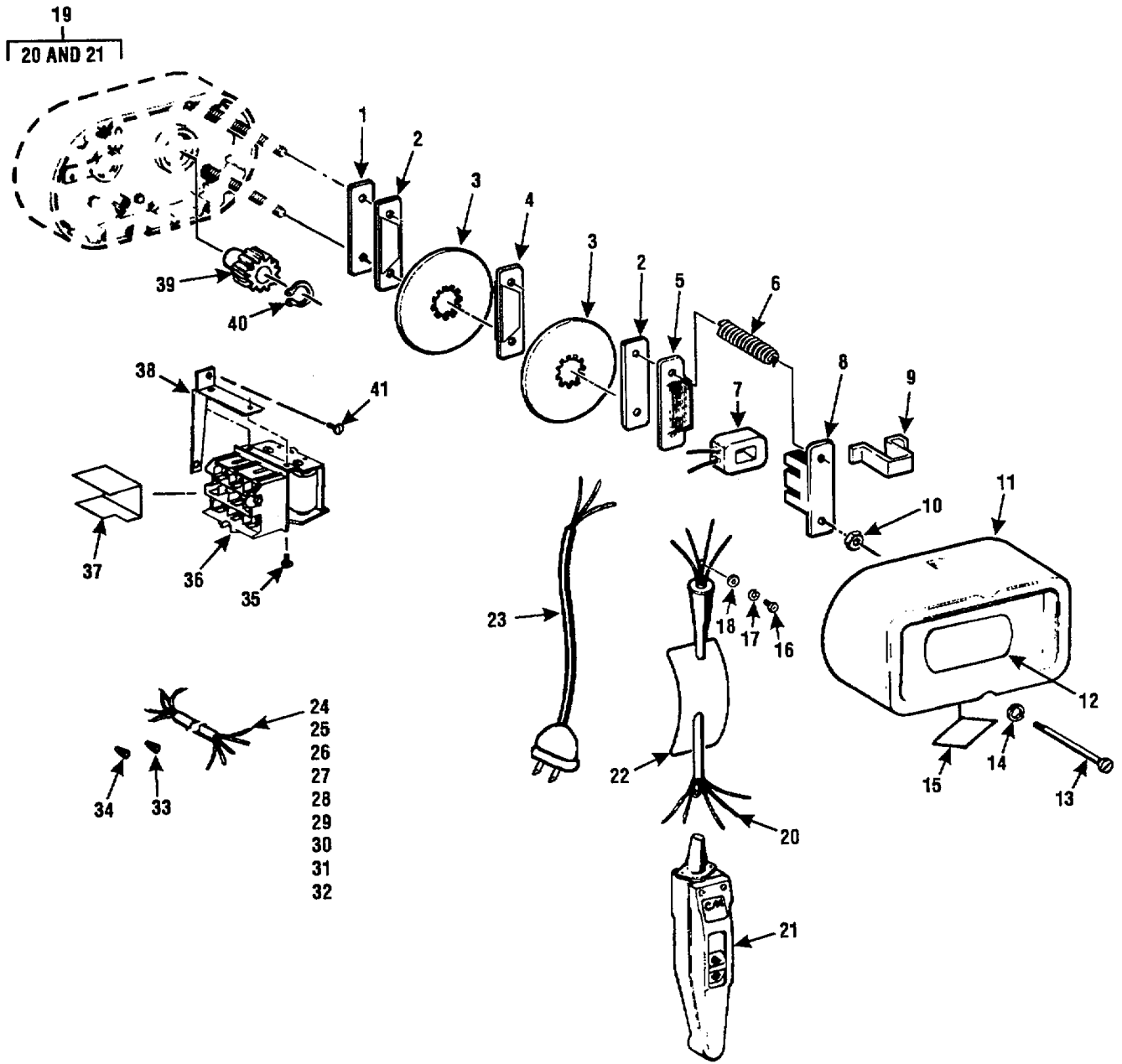

Figure 15. Electric Hoist, Brake End.

(1) ITEM NO	(2) SMR CODE	(3) CAGEC	(4) PART NUMBER	(5) DESCRIPTION AND USABLE ON CODES (UOC)	(6) QTY
GROUP 7320 BOOM AND ATTACHING PARTS					
FIG. 15 ELECTRIC HOIST, BRAKE END					
1	XBFZZ	12128	24741	PLATE, BRAKE.....	1
2	XBFZZ	12128	24603	PLATE, FRICTION.....	2
3	XBFZZ	12128	27817	DISC, BRAKE.....	2
4	XBFZZ	12128	24600	PLATE, FRICTION.....	1
5	XBFZZ	12128	24607	ARMATURE, BRAKE.....	1
6	XBFZZ	12128	24731	SPRING, BRAKE.....	2
7	XBFZZ	12123	51001	COIL, BRAKE.....	1
8	XBFZZ	12128	24606	FIELD, BRAKE.....	1
9	XBFZZ	12128	24738	STRAP, RETAIN-R.....	1
10	XBFZZ	12128	982442	NUT, PLAIN HEX.....	2
11	XBFZZ	12123	24757	COVER, BACK FRAME.....	1
12	XBFZZ	12128	24765	LABEL, WARNING.....	1
13	KFFZZ	12128	987395	SCREW, MACH, FIL HD 1/4-2GNC X 1 1/.....	2
14	KFFZZ	12128	940802	4 INCHES PART OF KIT P/N C309.....	2
15	XBFZZ	12128	24842	WASHER, LOCK 1/4 INCH HI-COLLAR.....	2
16	KFFZZ	12128	982688	PART UF KIT P/N C309.....	1
17	KFFZZ	12128	982226	DECAL, WARNING.....	1
18	KFFZZ	12128	927835	SCREW, MACH, FIL HD 1/4-20NC X 1/2.....	1
19	PAOZZ	12128	24614	INCH PART OF KIT P/N C306.....	1
20	XBFZZ	12128	51011	WASHER, LOCK 1/4 INCH PART OF KIT.....	1
21	XBOOO	12128	28600	P/N C36.....	1
22	XBOZZ	12128	81704	WASHER, FLAT 1/4 INCH PART OF KIT.....	1
23	XBFZZ	12128	24d40	P/N C3036.....	1
24	XBFZZ	12128	51692	CONTROL ASSEMBLY, PU.....	1
25	XBFZZ	12128	51659	CABLE, CONTROL.....	1
26	XBFZZ	12128	51533	CONTROL ASSEMBLY.....	1
27	XBFZZ	12128	51828	TAG, WARNING.....	1
28	XBFZZ	12128	51995	CORD, POWER.....	1
29	XBFZZ	12128	51996	LEAD, WIRE 16 GA, STRANDED X 1.88.....	1
30	XBFZZ	12128	51997	INCHES LONG, WHITE INSULATION.....	1
31	XBFZZ	12128	51831	LEAD, WIRE 16 GA, STRANDED X 4.....	3
32	XBFZZ	12128	51832	INCHES LONG, WHITE INSULATION.....	1
33	XBFZZ	12128	982473	LEAD, WIRE 16 GA, STRANDED X 2.25.....	1
34	XBFZZ	12128	982477	INCHES LONG, WHITE INSULATION.....	1
				LEAD, WIRE 16 GA, STRANDED X 7.....	1
				INCHES LONG, WHITE INSULATION.....	1
				LEAD, WIRE 16 GA, STRANDED X 4.....	1
				INCHES LONG, WHITE INSULATION.....	1
				LEAD, WIRE 16 GA, STRANDED X 4.....	1
				INCHES LONG, WHITE INSULATION.....	1
				LEAD, WIRE 16 GA, STRANDED X 17.....	1
				INCHES LONG, WHITE INSULATION.....	1
				LEAD, WIRE 16 GA, STRANDED X 24.....	1
				INCHES LONG, WHITE INSULATION.....	1
				WIRE NUT, SMALL.....	2
				WIRE NUT, LARGE.....	1

SECTION II					
(1)	(2)	(3)	(4)	(5)	(6)
ITEM	SMR		PART		
NO	CODE	CAGEC	NUMBER	DESCRIPTION AND USABLE ON CODES (UOC)	QTY
35	XBFZZ	12128	25858	SCREW, SELFTAP	2
36	XBFZZ	12128	28835	CONTACTOR ASSEMBLY	1
37	XBFZZ	12123	35881	INSULATOR.....	1
38	XBFZZ	12128	24021	BRACKET	1
39	XBFZZ	12123	27852	HUB, BRAK.....	1
40	XBFZZ	12128	27766	RING, RETAINING.....	1
41	XBFZZ	12128	982717	SCREW, MACH, FIL HD 1/4-200NC X 5/R	1
				INCH.....	

END OF FIGURE

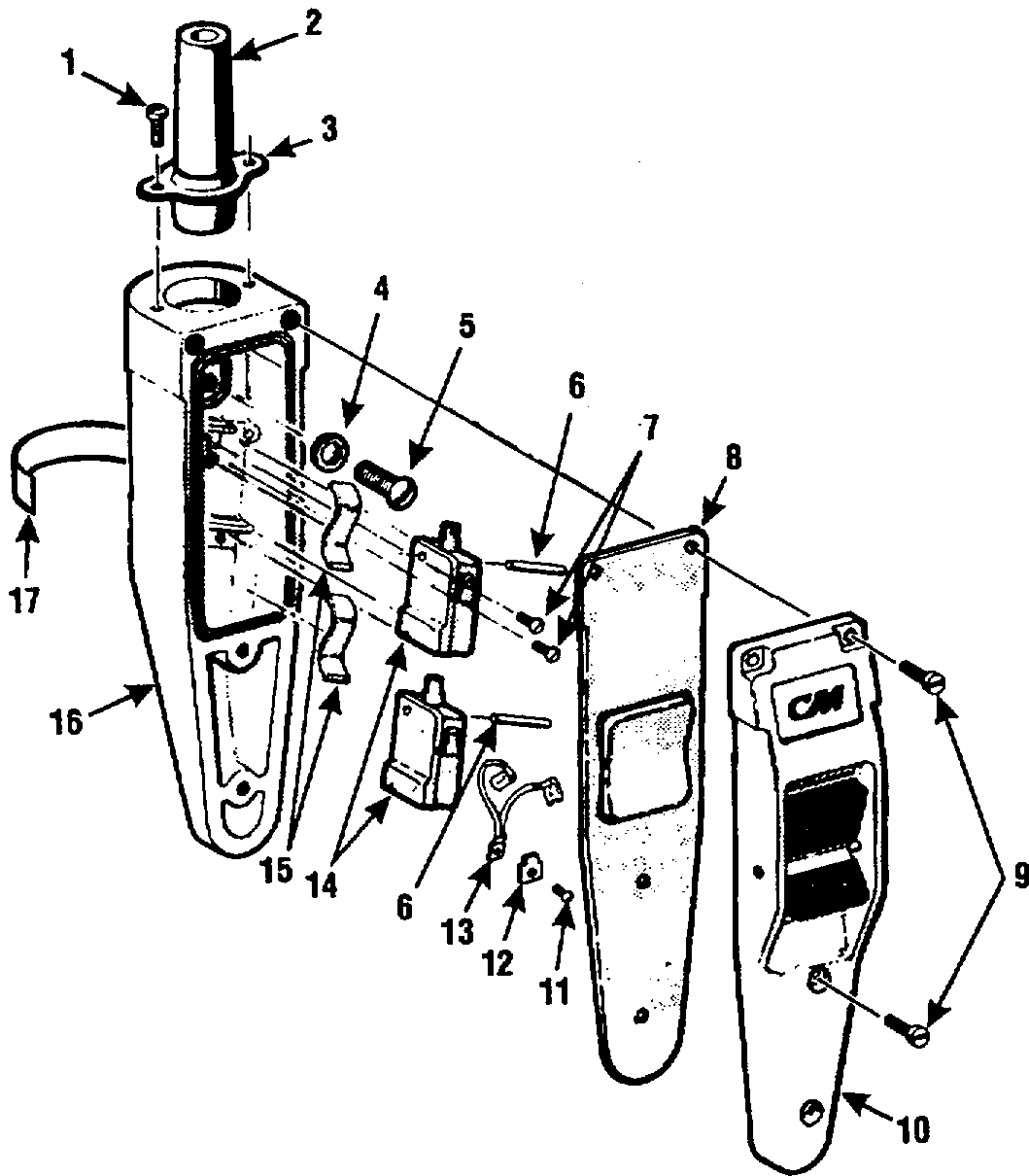

Figure 16. Electric Hoist, Controller.

SECTION II					
(1)	(2)	(3)	(4)	(5)	(6)
ITEM NO	SMR CODE	CAGEC	PART NUMBER	DESCRIPTION AND USABLE ON CODES (UOC)	QTY
GROUP 7320 BOOM AND ATTACHING PARTS					
FIG. 16 ELECTRIC HOIST CONTROLLER					
1	KFOZZ	12128	983738	SCREW, MACH NO. 3-32NC X 5/1 INCH	2
				PART OF KIT P/N 28627	
2	KFOZZ	12128	28730	GROMMET PART 09 KIT P/N 28627	1
3	KFOZZ	12128	28845	RING, RETAINER PART OF KIT P/N 28627	1
4	KFOZZ	12128	927835	WASHER, FLAT 1/4 INCH PART OF KIT	1
				P/N 51481	
5	KFOZZ	12128	927930	SCREW, MACH, RD HD 1/4-20NC X 1/2	1
				INCH PART OF KIT P/N 51481	
6	KFOZZ	12128	51353	PIN PART OF KIT P/N 5148	2
7	KFOZZ	12128	951726	SCREW, MACH PART OF KIT P/N 51481	2
3	XBOZZ	12128	28876	GASKET	1
9	KFOZZ	12128	983598	SCREW, MACH FIL HD NO. 8-32NC X 1/	4
				2 INCH PART OF KIT P/N 286271	
10	XBOZZ	12128	51477	COVER ASSEMBLY	1
11	KFOZZ	12128	951726	SCREW, MACH PART OF KIT P/N 51472	1
12	KFOZZ	12128	983713	TERMINAL PART OF KIT P/N 51472	1
13	KFOZZ	12128	51527	JUMPER ASSEMBLY PART OF KIT P/N	1
				51472	
14	KFOZZ	12128	51715	SWITCH PART OF KIT P/N 51472	2
15	KFOZZ	12128	51707	SPRING, LEAF PART OF KIT P/N 51481	2
16	XBOZZ	12128	28873	CASE, CONTROL	1
17	XBOZZ	12128	24842	DECAL, WARNING	1

END OF FIGURE

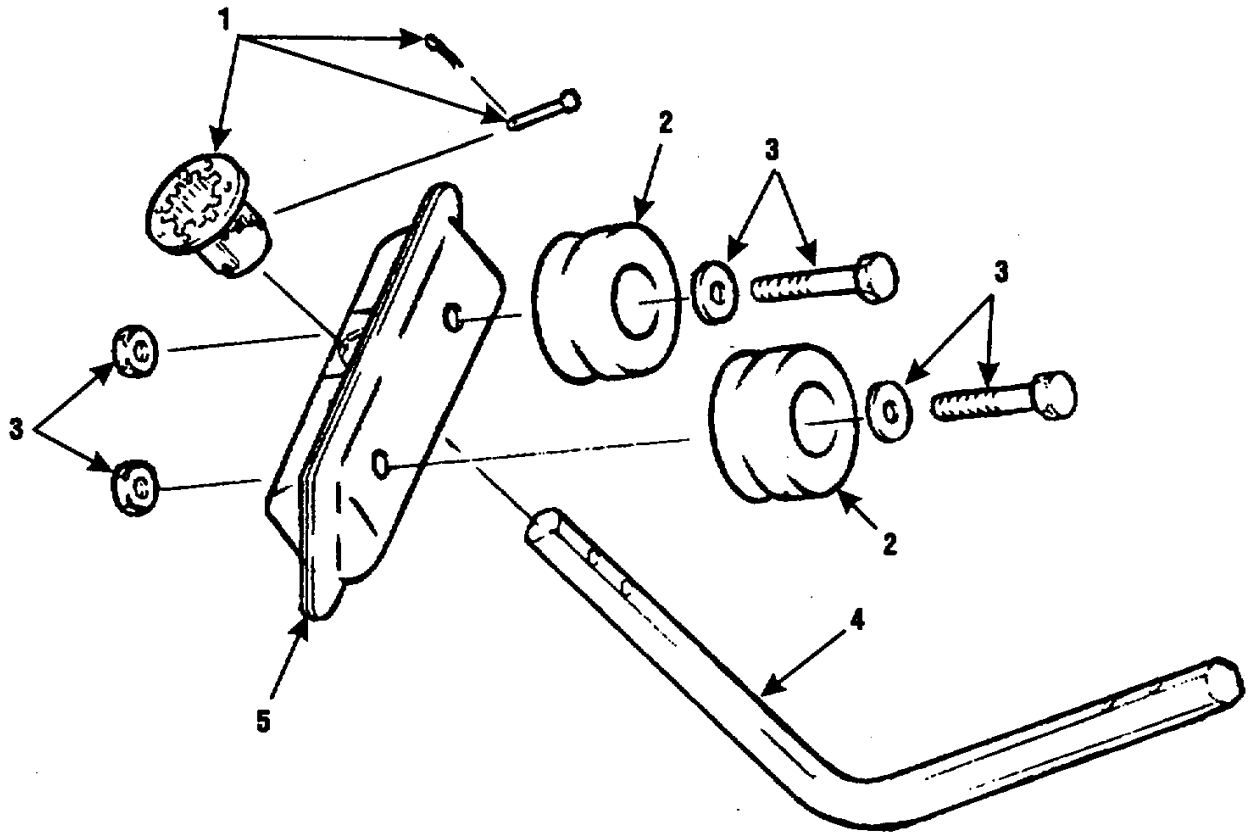

Figure 17. Trolley Assembly, Hoist.

SECTION II					
(1)	(2)	(3)	(4)	(5)	(6)
ITEM	SMR		PART		
NO	CODE	CAGEC	NUMBER	DESCRIPTION AND USABLE ON CODES (UOC)	QTY
GROUP 7320 800M AND ATTACHING PARTS					
FIG. 17 TROLLEY ASSEMBLY, HOIST					
1	XBOZZ	12128	32660	COLLAR, SHAFT	2
2	XBOZZ	12188	32660	TRACKWHEEL ASSEMBLY	4
3	XBOZZ	12188	32660	SCREW, ASSEMBLED WAS	4
4	XBOZZ	12188	32123	BRACKET, MOUNTING.....	1
5	XBOZZ	12123	32503	SIDE FRAME ASSEMBLY	2

END OF FIGURE

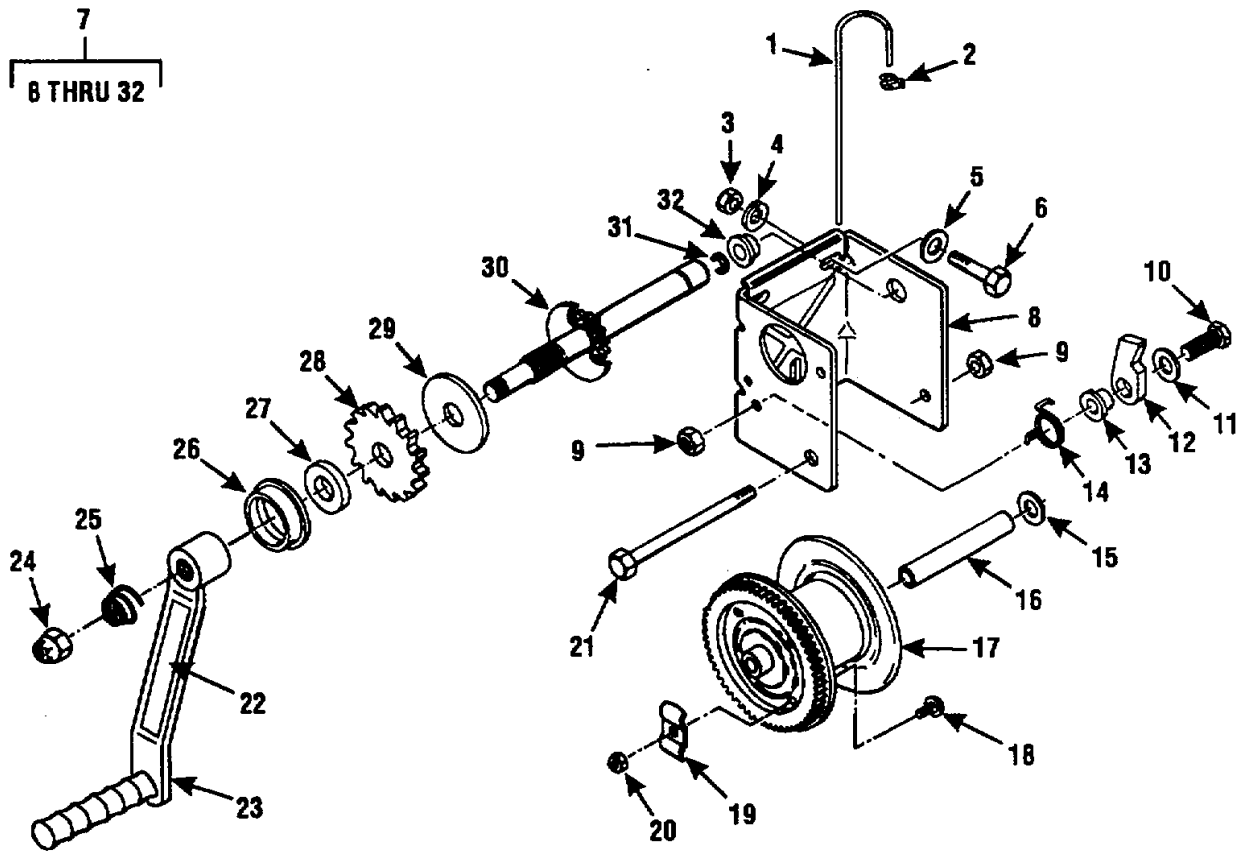

Figure 18. Winch Assembly.

SECTION II					
(1)	(2)	(3)	(4)	(5)	(6)
ITEM	SMR		PART		
NO	CODE	CAGEC	NUMBER	DESCRIPTION AND USABLE ON CODES (UOC)	QTY
GROUP 7320 BOOM AND ATTACHING PARTS					
FIG. 18 WINCH ASSEMBLY					
1	MFFZZ	11740	3000-144	CABLE, WIRE ROPE MAKE FROM: 3332T54, CAGEC 39428t CUT TO 14 FT LENGTH	2
2	PAOZZ	39428	3465T27	CLIP, WIRE ROPE.....	2
3	PAOZZ	96906	MS51967-8	NUT, PLAIN, HEXAGON 3/8- 16NC	6
4	PAOZZ	81718	H2525M	WASHER, LOCK 3/8 INCH SPLIT	6
5	PAOZZ	96906	MS27183-14	WASHER, FLAT 3/8 INCH	6
6	PAOZZ	80204	B1821BH038C150N	SCREW, CAP, HEXAGON H 3/8-16NC X 1 1/..... 2 INCHES.....	6
7	PAOZZ	72031	DL8800	WINCH, DRUM, HAND OPE	2
8	XBOZZ	72031	304342	BASE, WINCH	1
9	XBOZZ	72031	204803	NUT, SELF-LOCKING, HE	2
10	XBOZZ	72031	205167	BOLT, MACHINE,	1
11	XBOZZ	72031	205055	WASHER, FLAT.....	1
12	XBOZZ	72031	404409	PAWL	1
13	XBOZZ	72031	404166	SPACER, SLEEVE.....	1
14	XBOZZ	72031	204363	SPRING, HELICAL, TORS	1
15	XBOZZ	72031	204360	WASHER, FLAT 1/2 I.D. X 7/8 O.D. X 0.036 INCH THICK	1
16	XBOZZ	72031	204807	SPACER.....	1
17	XBOZZ	72031	304339	REEL, RATCHET	1
18	XBOZZ	72031	205017	BOLT, SQUARE NECK.....	1
19	XBOZZ	72031	404043	STRAP, RETAINING.....	1
20	XBOZZ	72031	205016	NUT, PLAIN, HEXAGON	1
21	XBOZZ	72031	203161	SHAFT, REEL	1
22	XBOZZ	72031	204358C	DECAL, INSTRUCTION.....	1
23	XBOZZ	72031	304231	HANDLE	1
24	XBOZZ	72031	205015	NUT, SELF-LOCKING, HE	1
25	XBOZZ	72031	204364	SPRING, HELICAL, COMP	1
26	XBOZZ	72031	204359	BUSHING SLEEVE	1
27	XBOZZ	72031	404163	.WASHER, FLAT.....	1
23	XBOZZ	72031	404164	RATCHET WHEEL	1
29	XBOZZ	72031	204362	PLATE, PRESSURE, WINC	1
30	XBOZZ	72031	304228	SHAFT, DRIVE.....	1
31	XBOZZ	72031	205116	RING, RETAINING.....	1
32	XBOZZ	72031	204012	BUSHING, SHAFT	1

END OF FIGURE

SECTION II					
(1)	(2)	(3)	(4)	(5)	(6)
ITEM NO	SMR CODE	CAGEC	PART NUMBER	DESCRIPTION AND USABLE ON CODES (UOC)	QTY
GROUP 94 KITS					
GROUP 9401 KITS AND RELATED PARTS					
XBFZZ	12128	C302		MOTOR HSG HOWE KIT	2
				SCREW, MACH, FIL HO (2) 13-1	
				WASHER, LOCK (2) 13-2	
XBFZZ	12128	C337		CUTOUT SWITCH KIT	1
				SCREW, MACH, RD HD (2) 13-9	
				SWITCH, STATIONARY (1) 13-6	
XBFZZ	12128	C349		CENTRIFUGAL KIT	1
				CENTRIFUGAL MECHANI (1) 13-7	
				SPACER (1) 13-8	
XBFZZ	12128	C336		CAPACITOR MTG KIT,.....	1
				SCREW, MACH, FIL HD(1) 13-19	
				SPRING, MOUNTING (1) 13-18	
PAOZZ	12128	45661		SNAP HOOK.....	2
				LATCH, SAFETY (1) 14-3	
				LATCH, SAFETY (1) 14-48	
				NUT, SELF LOCKING (1) 14-6	
				NUT, SELF LOCKING (2) 14-51	
				SCREW, MACH, RD HD (1) 14-4	
				SCREW, MACH, RD HD (2) 14-49	
				SPRING, LATCH (1) 14-5	
				SPRING, LATCH (1) 14-50	
XBFZZ	12128	C329		UPPER HOOK KIT.....	1
				COLLAR (1) 14-10	
				PIN (1) 14-11	
XBFZZ	12128	C304		LOOSE END HOWE KIT	1
				SCREW, CAP, HEX HD (1) 14-14	
				WASHER, FLAT (1) 14-12	
				WASHER, LOCK (1) 14-13	
XBFZZ	12128	C307		RETAINING KIT, BRG	1
				SCREW, SELFTAP RH (1) 14-30	
				WASHER, FLAT (1) 14-28	
				WASHER, LOCK (1) 14-29	
XBFZZ	12128	C328		CHAIN PIN KIT,.....	1
				PIN (1) 14-17	
				PIN, GROOVED (1) 14-18	
XBFZZ	12128	C309		BACK FRAME HOWE KIT	2
				SCREW, MACH, FIL HD(2) 15-13	
				WASHER, LOCK (2) 15-14	
XBFZZ	12128	C306		CABLE HDWE KIT,.....	1
				SCREW, MACH, FIL HD(1) 15-16	
				WASHER, LOCK (1) 15-17	
				WASHER, FLAT (1) 15-18	
XBOZZ	12128	28527		CONTROL STATION KIT,	1
				GROMMET (1) 16-2	
				RING, RETAINER (1) 16-3	
				SCREW, MACH (2) 16-1	
				SCREW, MACH FIL HO (4) 16-9	
XBOZZ	12128	51481		PARTS KIT, CONTROL.....	1

KIT-1

SECTION II					
(1)	(2)	(3)	(4)	(5)	(6)
ITEM	SMR		PART		
NO	CODE	CAGEC	NUMBER	DESCRIPTION AND USABLE ON CODES (UOC)	QTY
				PIN (2)	16-6
				SCREW, MACH, RD HO (1)	15-5
				SCREWS MACH (2)	16-7
				SPRING, LEAF (2)	16-15
				WASHER, FLAT (1)	16-4
XBOZZ	12128		51472	SWITCH KIT, CONTROL.....	1
				JUMPER ASSEMBLY (1)	16-13
				SCREW, MACH (1)	16-11
				SWITCH (2)	16-14
				TERMINAL (1)	16-12

END OF FIGURE

KIT-2

SECTION II					
(1)	(2)	(3)	(4)	(5)	(6)
ITEM	SMR		PART		
NO	CODE	CAGEC	NUMBER	DESCRIPTION AND USABLE ON CODES (UOC)	QTY
				GROUP 95 BULK	
				GROUP 9501 BULK ITEMS	
1	PAOZZ	51463	03-92569	WIRE MESH, KNITTED	14
				END OF FIGURE	

BULK-1

**CROSS- REFERENCE-INDEXES
NATIONAL STOCK NUMBER INDEX**

STOCK NUMBER	FIG.	ITEM	STOCK NUMBER	FIG.	ITEM
5310-00-003-9174	11	2	5340-01-057-9492	18	2
4010-01-002-2938	BULK	1	4720-01-117-8253	9	11
5305-00-068-0510	5	3	6585-01-117-9655	3	1
	7	14	4720-01-118-6088	1	10
5305-00-071-2071	9	18	5330-01-119-4407	9	4
5310-00-080-6004	1	3		10	1
	8	6		11	6
	18	5	5330-01-119-5091	9	8
3110-00-155-8432	13	5	5315-01-161-2695	4	15
4730-00-187-7602	1	7	5310-01-218-7137	7	1
4730-00-196-1512	9	12	3950-01-233-2393	18	7
5310-00-225-6993	8	9	5310-01-236-1717	6	9
5305-00-253-5614	2	5	3110-01-237-4870	14	23
5305-00-269-3205	1	5	3895-01-250-1615	4	20
2590-00-473-6331	1	1	3895-01-250-1616	4	13
4730-00-496-7535	9	13	2590-01-250-1878	4	21
5305-00-543-2866	8	5	3895-01-250-7198	4	12
5310-00-637-9541	1	4	3895-01-250-7199	4	19
	5	5	5306-01-283-3520	4	14
	6	3	3895-01-299-5739	4	17
	7	4	4730-01-337-0025	1	8
	18	4	3895-01-343-4505	11	4
5305-00-724-7220	6	10	4730-01-343-8422	9	1
5305-00-724-7222	9	3	4730-01-343-8472	4	10
5305-00-724-7224	9	20		11	12
	10	5	4730-01-343-8473	1	11
	11	5	5430-01-343-8522	11	11
	11	8	2510-01-343-8616	4	16
5305-00-725-2317	5	9	3110-01-343-8739	14	44
	6	7	3120-01-343-8773	14	45
	7	6	5815-01-344-0526	14	52
	8	2	5340-01-344-0558	9	14
	18	6	5340-01-344-0564	KIT	
5310-00-732-0558	5	4	5340-01-344-0679	4	11
	6	2	4730-01-344-0725	11	10
	7	5	4710-01-344-0790	10	6
	8	8	4710-01-344-0791	11	7
	18	3	3950-01-344-0804	12	1
5310-00-763-8920	6	8	5315-01-344-1025	14	53
	9	5	4820-01-344-1910	9	7
	9	21	9905-01-344-3788	2	2
	10	4	9905-01-344-3789	2	3
	11	1	4710-01-344-5339	9	2
	11	9	4710-01-344-5340	9	6
5310-00-758-0318	4	18	4710-01-344-5341	9	10
	7	2	4710-01-344-5342	9	19
	9	9	4710-01-344-5343	9	22
5305-00-846-5703	5	8	3040-01-344-6395	14	54
5310-00-914-6028	8	4	4820-01-344-9005	9	16
5340-00-968-4060	1	2	4710-01-345-1163	9	17

CROSS- REFERENCE-INDEXES
NATIONAL STOCK NUMBER INDEX

STOCK NUMBER	FIG.	ITEM	STOCK NUMBER	FIG.	ITEM
4710-01-345-1164	10	2			
5340-01-345-6243	9	15			
5340-01-346-3967	11	3			
3940-01-346-5185	12	3			
9905-01-348-1715	2	1			
4730-01-351-1570	1	9			
3895-01-350-3521	4	5			
9905-01-361-3396	2	4			
3950-01-413-0075	15	1			

**NATIONAL STOCK NUMBER AND PART NUMBER INDEX
PART NUMBER INDEX**

CAGEC	PART NUMBER	STOCK NUMBER	FIG.	ITEM
80204	81821BH038C100N	5305-00-068-0510	5	3
			7	14
80204	81821BH033C150N	5305-00-725-2317	5	9
			6	7
			7	6
			8	2
			13	6
80204	B18218H038C250N	5305-00-543-2866	8	5
80204	B18218H038C300N	5305-00-846-5703	5	8
80204	B18218H050C200N	5305-00-071-2071	9	13
80204	B18218H063C150N	5305-00-724-7220	6	10
80204	B18218H063C200N	5305-00-724-7222	9	3
80204	B18218H063C250N	5305-00-724-7224	9	20
			10	5
			11	5
			11	8
14959	CAP-150-2	4730-01-343-8472	4	10
			11	12
12128	C302		KIT	
12128	C304		KIT	
12128	C306		KIT	
12128	C307		KIT	
12128	C309		KIT	
12128	C323		KIT	
12128	C329		KIT	
12128	C336		KIT	
12128	C337		KIT	
12128	C349		KIT	
72031	DLB00	3950-01-233-2393	13	7
81718	H2525M	5310-00-637-9541	1	4
			5	5
			6	3
			7	4
			18	4
29215	L	5340-01-345-6243	9	15
45861	MODEL 41DRUMSLIN G	3940-01-346-5185	12	3
96906	MS14303-2P43	4730-01-351-1570	1	9
96906	MS21318-20	5305-00-253-5614	2	5
96906	MS27183-14	5310-30-080-6004	1	3
			8	6
			18	5
96906	MS27133-21	5310-00-323-8803	11	2
96906	MS39233-98	4730-00-137-7602	1	7
96906	MS51415-10	5310-01-236-1717	6	9
96906	MS51415-7	5310-01-218-7131	7	1
96906	MS51884-19		10	3
96906	MS51884-21		1	6
96906	M351922-16	5310-00-914-6028	8	4
96906	MS51922-33	5310-00-225-6993	d	9
96906	MS51953-241	4730-00-196-1512	9	12

**NATIONAL STOCK NUMBER AND PART NUMBER INDEX
PART NUMBER INDEX**

CAGEC	PART NUMBER	STOCK NUMBER	FIG.	ITEM
96906	MS51953-2418	4730-01-337-0025	1	8
96906	MS51967-14	5310-00-768-0318	4	18
			7	2
			9	9
96906	MS51967-20	5310-00-763-8920	6	8
			9	5
			9	21
			10	4
			11	1
			11	9
96906	MS519617-8	5310-00-732-0558	5	4
			6	2
			7	5
			18	3
95906	MS990725-55	5305-00-269-3206	1	5
00979	P50A12005	3110-00-155-8432	13	5
11740	ST-M-C-7	5315-01-151-2695	4	15
51463	03-925-89	4010-00-032-2933	BULK	1
88772	115T304SS-2	4730-01-343-3422	9	1
72031	203161		18	21
72031	204012		18	32
72031	204358C		18	22
72031	204359		18	26
72031	204360		18	15
72031	204362		18	29
72031	204363		18	14
72031	204364		18	25
72031	204803		18	9)
72031	204807		18	16
72031	205015		18	24
72031	205016		18	20
72031	205017		18	18
72031	205055		18	11
72031	205116		18	31
72031	205167		18	13
12128	24015		14	16
12128	24021		15	31
12128	2403		12	2
11218	24351		14	39
11218	24360		13	1
41592	24555-HOSE END-3 IN	4730-01-343-8473	1	11
12128	24504		13	4
12128	24600		15	4
12128	24633		15	2
12128	24636		15	3
12128	24607		15	5
12128	24614	3950-01-413-0075	15	19
12128	24620		14	25
12128	24633		13	11

NATIONAL STOCK NUMBER AND PART NUMBER INDEX
PART NUMBER INDEX

CAGEC	PART NUMBER	STOCK NUMBER	FIG.	ITEM
12128	24642		14	35
12128	24707		1	3
12128	24720		13	20
12128	24728		13	6
12128	24731		15	6
12128	24738		1	5
12128	24741		15	1
1212d	24753		13	7
12128	24757		15	11
12128	24755		15	12
12128	24770		13	16
12128	24785		14	19
12128	24840		15	23
11228	24842		13	10
			15	15
			16	17
00793	250A12006		14	36
12128	25858		15	35
12128	27008		14	22
12128	27009		14	33
12128	27028		14	56
12128	27291		13	15
12128	27292		13	14
12128	27360		14	21
12128	27361		14	10
41592	27755	5340-01-344-0558	9	14
12128	27703		14	8
12128	27716		13	17
12128	27747		14	24
12128	27753		13	18
12128	27765		14	37
12128	27766		15	40
12128	27767		14	34
12128	27790		13	12
12128	27805		14	11
12128	27817		15	3
12128	27852		15	39
12128	2788		14	1
12128	28007	3040-01-344-6395	14	54
12128	28600		15	21
12128	28627		KIT	
12128	28659		14	40
12128	28679		14	42
12128	28686		14	47
12128	28689		14	2
12128	28695		14	38
12128	28730		14	2
12128	28830		14	32
12128	28835		15	36
12128	28845		16	3
12128	28873		16	16

**NATIONAL STOCK NUMBER AND PART NUMBER INDEX
PART NUMBER INDEX**

CAGEC	PART NUMBER	STOCK NUMBER	FIG.	ITEM
12128	23876		16	8
41592	2951-4	4730-00-496-7535	16	13
38056	30-E1-60R-240-50 /550DFGF	6685-01-117-9655	9	1
11740	3000-1	4710-01-344-5341	9	10
11740	3000-10	4710-01-345-1164	10	2
11740	3000-103	3895-01-360-3521	4	5
11740	3000-104	5430-01-343-8522	11	11
11740	3000-109	9905-01-348-1715	2	1
11740	3000-11	4710-01-344-0790	10	6
11740	3000-110	9905-01-344-3788	2	2
11740	3000-111	9905-01-344-3769	2	3
11740	3000-112	9905-01-361-3396	2	4
11740	3000-113		6	6
11740	3000-114		6	4
11740	3000-115		6	1
11740	3000-116		6	5
11740	3000-118		7	3
11740	3000-119		7	11
11740	3000-12		4	11
11740	3000-120		7	7
11740	3000-121		7	13
11740	3000-122		7	8
11740	3000-123		7	9
11740	3000-124		7	10
11740	3000-125		7	12
11740	3000-126		5	7
11740	3000-127		5	10
11740	3000-128		5	2
11740	3000-129		5	5
11740	3000-13		4	12
11740	3000-130		5	13
11740	3000-131		5	12
11740	3000-132		5	12
11740	3000-133		5	6
11740	3000-134		8	10
11740	3000-135		8	7
11740	3000-136		8	1
11740	3000-137		8	3
11740	3000-138		4	6
11740	3000-138-1		4	7
11740	3000-139		4	1
11740	3000-139-1		4	2
11740	3000-14	3895-01-250-1616	4	13
11740	3000-140		4	4
			4	9
11740	3000-141		4	3
			4	8
11740	3000-144		18	1
11740	3000-15	3895-01-250-7199	4	19
11740	3000-16	3895-01-250-1615	4	20

**NATIONAL STOCK NUMBER AND PART NUMBER INDEX
PART NUMBER INDEX**

CAGEC	PART NUMBER	STOCK NUMBER	FIG.	ITEM
11740	3000-17	2590-01-250-1878	4	21
11740	3000-2	4710-01-345-1163	9	17
11740	3000-23	3895-01-299-5739	4	17
11740	3000-24	5306-01-283-3520	4	14
11740	3000-25	2510-01-343-8616	4	16
11740	3000-26	4710-01-344-0791	11	7
11740	3000-27	5340-01-346-3967	11	3
11740	3000-28	3895-01-343-4505	11	4
11740	3000-3	5330-01-119-5081	9	1
11740	3000-4	4710-01-344-5340	9	6
11740	3000-5	4710-01-344-5339	9	2
11740	3000-6	5330-01-119-4407	9	4
			10	1
11740	3000-7	4710-01-344-5343	9	22
11740	3000-8	4710-01-344-5342	9	19
11740	3000-9	4720-01-118-6088	1	10
72031	304228		18	30
72031	304231		18	23
72031	304339		18	17
72031	304342		18	q
12112	32123		17	4
12128	3222	3950-01-344-0804	12	1
12128	32603		17	5
12128	32655		17	2
12128	32657		17	3
12128	32660		17	1
39428	3465T27	5340-01-057-9492	18	2
12128	35881		15	37
16327	47067	4720-01-117-8253	9	11
72031	404043		13	19
72031	404163		18	27
72031	404164		18	29
72031	404166		18	13
72031	404409		1	12
12128	45401		14	46
12128	45661	5340-01-344-0564	KIT	
12128	45943	5315-01-344-1026	14	53
14959	488-1/2-2	4820-01-344-1910	9	7
12128	51001		15	7
12128	51011		15	20
12128	51353		16	6
12128	51472		KIT	
12128	51477		16	10
12128	51481		KIT	
12128	51527		16	13
12128	51533		15	26
12128	51659		15	25
12128	51692		15	24
12128	51707		16	15
12128	51715		16	14

NATIONAL STOCK NUMBER AND PART NUMBER INDEX
PART NUMBER INDEX

CAGEC	PART NUMBER	STOCK NUMBER	FIG.	ITEM
12128	51828		15	27
12128	51831		15	31
12128	51832		15	32
12128	51995		15	29
12128	51996		15	29
12128	51997		15	30
14959	555-2	4730-01-344-0725	11	10
29215	601-5J-3	4820-01-344-9005	9	16
19207	6566675	2590-00-473-6331	1	1
12128	81704		15	22
12128	82003		13	13
12128	82280		14	3
			14	43
12128	82638		14	20
12128	85832		14	15
12128	85944-10.5		14	55
12128	86171		14	5
			14	05
12128	8690527	5340-00-968-4060	1	2
12128	88429	3110-01-237-4870	14	23
12128	88440		14	41
12128	88485	3110-01-343-8739	14	44
12128	924787		14	13
12128	927755		14	9
12128	927764		14	14
12128	927835		15	15
			16	4
12128	927930		16	5
12128	940802		13	2
			15	14
12128	940822		13	1
12128	940837		14	26
12128	945921	3120-01-343-8773	14	45
12128	951725		16	7
			16	11
12128	954802		14	12
12128	932105		14	23
12128	982226		14	13
			15	17
12128	982442		15	10
12128	982454		14	27
12128	982473		15	33
12128	982477		15	34
12128	982526		14	43
12128	982627		14	6
			14	51
12128	982688		13	19
			15	14
12128	982699		14	31
12128	982717		15	41
12128	983541		13	21

NATIONAL STOCK NUMBER AND PART NUMBER INDEX
PART NUMBER INDEX

CAGEC	PART NUMBER	STOCK NUMBER	FIG.	ITEM
12128	983598		16	9
12128	983713		16	12
12128	983738		16	1
12128	983764		14	17
12128	983772	5315-01-344-0526	14	52
12128	986285		14	29
12128	987395		15	13
12128	987448		14	4
			14	49
12128	987519		14	30
12128	987523		13	9
12128	987554		14	7

CROSS REFERENCE INDEXES

FIG.	ITEM	FIGURE AND ITEM NUMBER INDEX STOCK NUMBER	CAGEC	PART NUMBER
BULK	1	4010-00-032-2938	51463	03-92589
KIT			12123	C302
KIT			12128	C304
KIT			12128	C306
KIT			12128	C307
KIT			12128	C309
KIT			12128	C328
KIT			12128	C329
KIT			12128	C336
KIT			12128	C337
KIT			12128	C349
KIT			12128	28627
KIT			12128	51472
KIT			12128	51481
KIT		5340-01-344-0564	12128	45661
1	1	2590-00-473-6331	19207	6566675
1	2	2540-00-968-4060	19207	8690527
1	3	5310-00-080-6004	96906	MS27183-14
1	4	5310-00-637-9541	81718'	H2525M
1	5	5305-00-269-3206	96906	MS90725-55
1	6		96906	MS51884-21
1	7	4730-00-187-7602	96906	MS39233-9B
1	8	4730-01-337-0025	96906	MS51953-241B
1	9	4730-01-351-1570	96906	MS14303-2P48
1	10	4720-01-118-6088	11740	3000-9
1	11	4730-01-343-8473	41592	245SS-HOSE END-3 IN
2	1	9905-01-348-1715	11740	3000-109
2	2	9905-01-344-3788	11740	3000-110
2	3	9905-01-344-3789	11740	3000-111
2	4	9905-01-361-3396	11740	3000-112
2	5	5305-00-253-5614	96906	MS21318-20
3	1	6685-01-117-9655	38056	30-E1-60R-240 50 /55CDEG F
4	1		11740	3000-139
4	2		11740	3000-139-1
4	3		11740	3000-141
4	4		11740	3000-140
4	5	3895-01-360-3521	11740	3000-103
4	6		11740	3000-138
4	7		11740	3000-138-1
4	d		11740	3000-141
4	9		11740	3000-140
4	10	4730-01-343-8472	14959	CAP-150-2
4	11	5340-01-344-0679	11740	3000-12
4	12	3895-01-250-7198	11740	3000-13
4	13	3895-01-250-1616	11740	3000-14
4	14	5306-01-283-3520	11740	3000-24
4	15	5315-01-161-2695	11740	ST-M-C-7
4	16	2510-01-343-8616	11740	3000-25
4	17	3895-01-299-5739	11740	3000-23

CROSS REFERENCE INDEXES

FIG.	ITEM	FIGURE AND ITEM NUMBER INDEX STOCK NUMBER	CAGEC	PART NUMBER
4	18	5310-00-768-0318	96906	MS51967-14
4	19	3895-01-250-7199	11740	3000-15
4	20	3895-01-250-1615	11740	3000-16
4	21	2590-01-250-1878	11740	3000-17
5	1		11740	3000-128
5	2		11740	3000-129
5	3	5305-00-068-0510	80204	31821BH038C100N
5	4	5310-00-732-0558	96906	MS51967-3
5	5	5310-00-637-9541	81718	H2525M
5	6		11740	3000-132
5	7		11740	3000-126
5	8	5305-00-846-5703	80204	31821BH038C300N
5	9	5305-00-725-2317	80204	B1821BH038C150N
5	10		11740	3000-127
5	11		11740	3000-133
5	12		11740	3000-131
5	13		11740	3000-130
6	1		11740	3000-115
6	2	5310-00-732-0553	96906	MS51967-8
6	3	5310-00-637-9541	81718	H2525M
6	4		11740	3000-114
6	5		11740	3000-116
6	6		11740	3000-113
6	7	5305-00-725-2317	30204	B1321BH036C150N
6	3	5310-00-763-8920	96906	MS51967-20
6	9	5310-01-236-1717	96906	MS51415-10
6	10	5305-00-724-7220	80204	B1821BH063C15CN
7	1	5310-01-218-7137	96936	MS51415-7
7	2	5310-00-768-0318	96906	MS51967-14
7	3		11740	3000-113
7	4	5310-00-637-9541	81718	H2525M
7	5	5310-00-732-0556	96906	MS51967-8
7	6	5305-00-725-2317	80204	31821BHO38C150N
7	7		11740	3000-120
7	6		11740	3000-122
7	9		11740	3000-123
7	10		11740	3000-124
7	11		11740	3000-119
7	12		11740	3000-125
7	13		11740	3000-121
7	14	5305-00-068-0510	80204	81821HH038C100N
8	1		11740	3000-136
8	2	5305-00-725-2317	80204	B1821BH038C150N
8	3		11740	3000-137
8	4	5310-00-914-6028	96906	MS51922-18
8	5	5305-00-543-2866	80204	81821BH038C250N
8	6	5310-00-080-6004	96906	MS27183-14
8	7		11740	3000-135
8	8	5310-00-732-0558	96906	MS51967-8
8	9	5310-00-225-6993	96906	MS51922-33
8	10		11740	3000-134

CROSS REFERENCE INDEXES

FIG.	ITEM	FIGURE AND ITEM NUMBER INDEX STOCK NUMBER	CAGEC	PART NUMBER
9	1	4730-01-343-6422	83772	115T304SS-2
9	2	4710-01-344-5339	11740	3000-5
9	3	5305-00-724-7222	80204	B1821BHO63C200N
9	4	5330-01-119-4407	11740	3000-6
9	5	5310-00-763-8920	96906	MS51967-20
9	6	4710-01-344-5340	11740	3000-4
9	7	4820-01-344-1910	14959	488-1/2-2
9	8	5330-01-119-5081	11740	3000-3
9	9	5310-00-768-0318	96906	M551967-14
9	10	4710-01-344-5341	11740	3000-1
9	11	4720-01-117-8253	16327	4Z067
9	12	4733-00-196-1512	96906	MS51953-241
9	13	4730-00-496-7535	41592	2951-4
9	14	5340-01-344-0558	41592	277SS
9	15	5340-01-345-6243	29215	L
9	16	4820-01-344-9005	29215	601-SJ-3
9	17	4710-01-345-1163	11740	3000-2
9	18	5305-00-071-2071	80204	B1821BH050C200N
9	19	4710-01-344-5342	11740	3000-8
9	20	5305-00-724-7224	80204	818218H063C250N
9	21	5310-00-763-8920	96906	MS51967-20
9	22	4710-01-344-5343	11740	3000-7
10	1	5330-01-119-4407	11740	3000-6
10	2	4710-01-345-1164	11740	3000-10
10	3		95906	MS51884-19
10	4	5310-00-763-8920	96906	MS51967-20
10	5	5305-00-724-7224	80204	818218H063C250N
10	6	4710-31-344-0790	11740	3000-11
11	1	5310-00-763-8920	96906	MS51967-20
11	2	5310-00-823-8803	96906	MS27183-21
11	3	5340-01-346-3967	11740	3000-27
11	4	3895-01-343-4505	11740	3000-28
11	5	5305-00-724-7224	80204	B18213H063C250N
11	6	5330-01-119-4407	11740	3000-6
11	7	4710-01-344-0791	11740	3000-26
11	8	5305-00-724-7224	80204	B1821BHO63C250N
11	9	5310-00-763-8920	96906	MS51967-20
11	10	4730-01-344-0725	14959	555-2
11	11	5430-01-343-8522	11740	3000-104
11	12	4730-01-343-8472	14959	CAP-150-2
12	1		12128	3222
12	2		12128	2403
12	3	3940-01-346-5185	45861	MODEL 41DRUMSLIN G
13	1		12128	940822
13	2		12128	940802
13	3		12128	24707
13	4		12128	24504
13	5		12128	82001
13	6		12128	24728
13	7		12128	24753

CROSS REFERENCE INDEXES

FIG.	ITEM	FIGURE AND ITEM NUMBER INDEX STOCK NUMBER	CAGEC	PART NUMBER
13	8		12128	24360
13	9		12128	987523
13	10		12128	24842
13	11		12128	24633
13	12		12128	27790
13	13		12128	82003
13	14		12128	27292
13	15		12128	27291
13	16		12128	24770
13	17		12128	27716
13	18		12128	27753
13	19		12128	932688
13	20		12128	24720
13	21		12128	983541
14	1		12128	2788
14	2		12128	28689
14	3		12128	82280
14	4		12128	987448
14	5		12128	86171
14	6		12128	982627
14	7		12128	987554
14	3		12128	27703
14	9		12128	927755
14	10		12128	27361
14	11		12128	27805
14	12		12128	954802
14	13		12128	982226
14	14		12128	927764
14	15		12128	85832
14	16		12128	24015
14	17		12128	983764
14	18		12128	924787
14	19		12128	24785
14	20		12128	82638
14	21		12128	27360
14	22		12128	27008
14	23		12128	88429
14	24		12128	27747
14	25		12128	24620
14	26		12128	940837
14	27		12128	982454
14	28		12128	982106
14	29		12128	986285
14	30		12128	987519
14	31		12128	982699
14	32		12128	28830
14	33		12128	27009
14	34		12128	27767
14	35		12128	24642
14	36		12128	82001
14	37		12128	27765

CROSS REFERENCE INDEXES

FIG.	ITEM	FIGURE AND ITEM NUMBER INDEX STOCK NUMBER	CAGEC	PART NUMBER
14	36		12128	28695
14	39		12128	24351
14	40		12128	28669
14	41		12128	88440
14	42		12128	28679
14	43		12128	982526
14	44		12128	88485
14	45		12128	945921
14	46		12128	45401
14	47		12128	28686
14	48		12128	82280
14	49		12128	987448
14	50		12128	86171
14	51		12128	982627
14	52		12128	983772
14	53		12128	45943
14	54		12128	28007
14	55		12128	85944-10.5
14	56		12128	27028
15	1		12128	24741
15	2		12128	24603
15	3		12128	27817
15	4		12128	24600
15	5		12128	24607
15	6		12128	24731
15	7		12128	51001
15	8		12128	24606
15	9		12128	24738
15	10		12128	982442
15	11		12128	24757
15	12		12128	24765
15	13		12128	987395
15	14		12128	940802
15	15		12128	24842
15	16		12128	982688
15	17		12128	982226
15	18		12128	927835
15	19	3950-01-413-0075	12128	24614
15	20		12128	51011
15	21		12128	28600
15	22		12128	31704
15	23		12128	24840
15	24		12128	51692
15	25		12128	51659
15	26		12128	51533
15	27		12128	51328
15	26		12128	51995
15	29		12128	51996
15	30		12128	51997
15	31		12128	51831
15	32		12128	51832

CROSS REFERENCE INDEXES

FIG.	ITEM	FIGURE AND ITEM NUMBER INDEX STOCK NUMBER	CAGEC	PART NUMBER
15	33		12128	982473
15	34		12128	982477
15	35		12128	25858
15	36		12128	28835
15	37		12128	35881
15	38		12128	24021
15	39		12128	27852
15	40		12128	27766
15	41		12128	982717
16	1		12128	983738
16	2		12128	28730
16	3		12128	28845
16	4		12128	927835
16	5		12128	927930
16	6		12128	51353
16	7		12128	951726
16	8		12128	28876
16	9		12128	983598
16	10		12128	51477
16	11		12128	951726
16	12		12128	983713
16	13		12128	51527
16	14		12128	51715
16	15		12128	51707
16	16		12128	28873
16	17		12128	24842
17	1		12128	32660
17	2		12128	32655
17	3		12128	32657
17	4		12128	32123
17	5		12128	32603
18	1		11740	3000-144
18	2	5340-01-057-9492	39423	3465T27
18	3	5310-00-732-0558	96906	MS51967-8
18	4	5310-00-637-9541	81718	H2525M
18	5	5310-00-080-6004	96906	MS27183-14
18	6	5305-00-725-2317	80204	81821PH038C15ON
18	7	3950-01-233-2393	72031	DLB800
18	8		72031	304342
18	9		72031	204803
18	10		72031	205167
18	11		72031	205055
18	12		72031	404409
13	13		72031	404166
18	14		72031	204363
18	15		72031	204360
18	16		72031	204807
18	17		72031	304339
13	18		72031	205017
13	19		72031	404043
18	20		72031	205016

CROSS REFERENCE INDEXES

FIG.	ITEM	FIGURE AND ITEM NUMBER INDEX STOCK NUMBER	CAGEC	PART NUMBER
18	21		72031	203161
18	22		72031	204358C
18	23		72031	304231
18	24		72031	205015
18	25		72031	204364
18	26		72031	204359
18	27		72031	404163
18	28		72031	404164
18	29		72031	204362
18	30		72031	304228
18	31		72031	205116
18	32		72031	204012

**APPENDIX B
 SUPPLEMENTAL OPERATION, MAINTENANCE
 AND REPAIR PARTS INSTRUCTIONS
 For
 MELTER, ASPHALT, SKID MOUNTED, HOT OIL CIRCULATING,
 MODEL STMD-3000A
 TABLE OF CONTENTS**

	Paragraph	Page
Section I	GENERAL	
	Purpose	1-1 B-2
	Scope.....	1-2 B-2
	NDI Acquisition	1-3 B-2
	Description.....	1-4 B-2
	Operational Concept.....	1-5 B-2
	Status.....	1-6 B-2
	Equipment Publications	1-7 B-2
	Personnel Training	1-8 B-2
	Logistic Assistance	1-9 B-2
	Warranty	1-10 B-2
	Reporting of Errors	1-11 B-2
Section II	MAINTENANCE	
	Maintenance Structure	2-1 B-3
	Maintenance Allocation Chart (MAC)	2-2 B-3
	Quality Deficiency Report (QDR) and Equipment Improvement Recommendation (EIR)	2-3 B-3
	Maintenance Expenditure Limits (MEL).....	2-4 B-3
	Preservation, Packing, and Marking.....	2-5 B-3
	Destruction to Prevent Enemy Use	2-6 B-3
	Basic Issue Item List (BIL)	2-7 B-3
	Maintenance and Operating Supply List.....	2-8 B-3
	Tool and Test Equipment Requirements	2-9 B-3
	Maintenance Forms and Records	2-10 B-3
	Lubrication	2-11 B-3
Section III	REPAIR PARTS SUPPLY	
	General.....	3-1 B-5
	Forms Used to Request Supplies.....	3-2 B-5
	Local Purchase.....	3-3 B-5

Section I - GENERAL

1-1. PURPOSE:

To provide user and support personnel Supplemental Operator Maintenance and Repair Parts Instructions that have special application to Non-Development Items (NDI) of equipment.

1-2. SCOPE:

This SOMARPI is not intended to be complete nor a comprehensive document on the Melter, Asphalt, Skid Mounted, Hot Oil Circulating, Model STMD-3000A, hereinafter called the Asphalt Melter. It is only intended to highlight and summarize the important elements of operation and maintenance.

1-3. NDI ACQUISITION:

Under the Nondevelopment Acquisition Process, the asphalt melter will be referred to as a commercially available Category B--off-the-shelf item, modified to satisfy Army Requirements and/or performance standards.

1-4. DESCRIPTION:

The asphalt melter consists of a dual de-drumming tunnel and a 3000 gallon capacity, heated storage tank. The tunnel is constructed to handle a maximum of six, 55 gallon drums at one time, with a melting rate of 750 gallons per hour of 85-100 penetration asphalt cement. The melted asphalt cement can be maintained in the storage tank at pouring temperature (235 degrees F), and transferred to bulk storage tanks or distributors by means of a separately supplied asphalt pump. The tunnel and storage tank are equipped with heat dissipating coiled piping, interconnected with removable external piping and valves to permit control of heat transfer medium. A separately supplied heat supply must provide 1, 000, 000 BTU per hour to the melter.

Circulating hot oil is recommended as the most efficient heat transfer medium. A loading platform with an electric hoist to assist the operator in loading asphalt drums is secured to the front of the melter. A ladder provides access to the load platform. A discharge chute is attached to the rear to receive empty drums. A gate on the bottom of the discharge chute holds the empty drums from one charge of the tunnel, allowing controlled removal of empty drums.

1-5. OPERATIONAL CONCEPT:

The asphalt melter will be utilized in construction, repair,

and maintenance of roads, shoulders, and airport runways. The asphalt melter supports the engineer mission performed by the Engineer Support Equipment Company, Engineer Battalion (Heavy), Engineer Battalion (ABN), and Engineer Utility Team.

1-6. STATUS:

The asphalt melter replaces the Chausse Model STMD3000.

1-7. EQUIPMENT PUBLICATIONS:

The contractor shall overpack and ship with each end item, two (2) sets of the final approved manual and two (2) copies of Government furnished Warranty Technical Bulletin (WTB).

1-8. PERSONNEL TRAINING:

a. MOS Requirements:

(1) Operator: MOS 62H Concrete and Asphalt Equipment Operator (Con & Asphalt Eq Op).

(2) Unit Maintenance: MOS 62B Construction Equipment Repairer (Const Equip Rep).

(3) Intermediate (DS/GS) Maintenance: MOS 62B Construction Equipment Repairer (Const Equip Rep).

b. New Equipment Training: New Equipment Training Teams (NETTs) are available to major field commands. Request for NETTs should be forwarded to Commander, U.S. Army-Tank-automotive and Armament Command (TACOM), ATTN: AMSTA-KL, Warren, MI 48397-5000. Training teams should be requested only when trained personnel are not available in the command to operate and/or maintain the asphalt melter.

1-9. LOGISTIC ASSISTANCE:

U.S. Army Tank-automotive and Armament Command (TACOM) Logistic Assistance Representatives (LARs) stationed at CONUS and OCONUS Installations are available to give on-site training and/or technical assistance.

1-10. WARRANTY:

The contractor warrants that for 18 months after acceptance, all end items furnished under this contract will be free from defects in materials and workmanship and will conform with all requirements of this contract (Reference Appendix C).

Section II. MAINTENANCE

2-1. THE MAINTENANCE STRUCTURE:

There are four levels of maintenance: Unit, Direct Support, General Support, and Depot. These four levels of maintenance form the baseline for determining task assignments at each level. However, the number of maintenance levels may be tailored to accommodate a specific material system or commodity grouping when justified.

a. Unit Maintenance: Each combat, combat support, and combat service support activity is authorized an organic material maintenance element (i.e., crew/operator and maintenance personnel) to perform authorized unit maintenance operations on equipment assigned to or used by it to accomplish its mission.

b. Direct Support Maintenance: Divisional and nondivisional direct support units are authorized in the Army force structure to provide direct support maintenance service to the Army in the field. One-stop service, to the extent practical, is the goal of these units.

c. General Support Maintenance: General support maintenance operations primarily are aimed at the repair of end items of modules for return to the local area or theater stocks of the support of the direct exchange program. Normally, general support units operate in shops and are considered movable, but not mobile.

d. Depot Maintenance: Depot maintenance operations support both the overall Army inventory management program and the combat forces. They are used as an alternative or a supplement to new procurement as a source of serviceable assets to meet Army material requirements.

2-2. MAINTENANCE ALLOCATION CHART (MAC):

The Maintenance Allocation Chart (MAC) will be the primary tool for assigning tasks within the levels of the Army maintenance system.

2-3. QUALITY DEFICIENCY REPORT (QDR) AND EQUIPMENT IMPROVEMENT RECOMMENDATION (EIR):

All Army material is subject to QDR and EIR. The purpose of submitting a QDR is to report conditions which are the result of below standard quality workmanship. This purpose of an EIR is to suggest material improvements in design, operations, or manufacture. Reporting instructions for QDRs and EIRs are contained in DA PAM 738-750 and DA PAM 738-

751.

2-4. MAINTENANCE EXPENDITURE LIMITS (MEL):

The average life expectancy for the Asphalt Melter is 15 years.

PRODUCTION YEAR	EXPENDITURE LIMITS					
	50%	45%	40%	35%	30%	20%
1995	2005	2006	2007	2008	2009	2010

2-5. PRESERVATION, PACKING, AND MARKING:

The items destined for POMCUS or long term storage at CONUS Depots, the preservation, packing and marking shall be level A/A in accordance with MIL-D-771. For items destined for OCONUS for immediate use, the preservation, packing and marking shall be level B/B in accordance with MIL-D-771. For items destined for CONUS for immediate use, the preservation, packing and marking shall be commercial in accordance with MIL-D-771.

2-6. DESTRUCTION TO PREVENT ENEMY USE:

Refer to TM 750-244-6, Procedures For Destruction of Tank-Automotive Equipment to Prevent Enemy Use (U.S. Army Tank-automotive and Armament Command).

2-7. BASIC ISSUE ITEM LIST (BIIL):

Refer to the BIIL, Appendix F, for listing of items issued with the asphalt melter.

2-8. MAINTENANCE AND OPERATING SUPPLY LIST:

Not required.

2-9. TOOL AND TEST EQUIPMENT REQUIREMENTS:

See Appendix D, Section III, Maintenance Allocation Chart (MAC).

2-10. MAINTENANCE FORMS AND RECORDS:

Operational, maintenance, and historical records will be maintained as required by the current TM 38-750, the Army Maintenance Management Systems (TAMMS).

2-11. LUBRICATION:

See Chapter 3, for lubrication requirements of the asphalt melter.

THIS PAGE CURRENTLY NOT AVAILABLE FOR DIGITIZATION

PAGE #
B-5

APPENDIX C - WARRANTY PROGRAM

C-1. The owning units must make a conscientious effort to use warranty items to their full-rated potential during the effective warranty time period. This is necessary to uncover defective or deficient material within the time period in which remedy can be effected, with the manufacturer bearing cost of retrofit, repair, or replacement.

C-2. Warranty Technical Bulletin TB 5-3895-368-12 (overpacked with each item shipped) tells you how to make and submit Warranty Claim Actions (WAC) for the Asphalt Melter, NSN 3895-01-332-3024, Model STMD-3000A.

C-1/(C-2 blank)

APPENDIX D - MAINTENANCE ALLOCATION CHART

Section I. INTRODUCTION

D-1. GENERAL.

a. This section provides a general explanation of all maintenance levels.

b. Section II designates authority and responsibility for the performance of maintenance functions on the identified end item of component and the work measurement level. The application of the maintenance functions to the end item or component will be consistent with the capacities and capabilities of the designated maintenance levels.

c. Section III lists the tools and test equipment (both special tools and common tools and common tool sets) required for each maintenance function as referenced from Section II.

d. Section IV contains supplemental instructions or explanatory notes for a particular maintenance function.

D-2. EXPLANATION OF COLUMNS IN SECTION II.

a. Column 1, Group Number. Column 1 lists functional grouping codes, the purpose of which is to index material for ready identification. The basic or two-digit code identifies the major assembly and the next two digits identify the subassembly and/or part within the major assembly.

b. Column 2, Component/Assembly. Column 2 contains the names of components, assemblies, subassemblies, and modules for which maintenance is authorized.

c. Column 3, Maintenance Function. Column 3 lists the functions to be performed on the item listed in Column 2. (For detailed explanation of these functions, see Paragraph D-5).

d. Column 4, Maintenance Level. Column 4 specifies the average total manhours required to perform the function listed in Column 3. For example, if it takes two people five hours to complete the function, the figure would be ten. This figure represents the time it takes to perform maintenance and restore the item to serviceable condition. It includes disassembly, troubleshooting, quality assurance and assembly. (For detailed explanation of maintenance levels, see Paragraph D-6).

e. Column 5, Tools and Equipment. Column 5

specifies by code the special tools, common tools sets, test equipment, and support equipment (Section III) required to perform the maintenance functions.

f. Column 6, Remarks. Column 6 specifies by code the Remarks (Section IV) pertinent to the maintenance functions.

D-3. EXPLANATION OF COLUMNS IN SECTION III.

a. Tools or Test Equipment Reference Code. This column consists of a code corresponding with a code used in the MAC, Section II, Column 5.

b. Maintenance Level. This column shows the lowest levels of maintenance authorized to use the tools or test equipment.

c. Nomenclature. This column lists the name or identification of the tools or test equipment.

d. National/NATO Stock Number. This column list the NSN of the tools or test equipment.

e. Tool Number. This column list the Line Item Number (LIN).

D-4. EXPLANATION OF COLUMNS IN SECTION IV.

a. Reference Code. This column list the code entered in Section II, Column 6.

b. Remarks. This column list information pertinent to the maintenance function being performed, as indicated in the MAC, Section II, Column 3.

D-5. MAINTENANCE FUNCTIONS. Maintenance functions will be limited to and defined as follows:

a. Inspect. To determine the serviceability of an item by comparing its physical, mechanical, and/or electrical characteristics with established standards through examination (e.g., by sight, sound, or feel).

b. Test. To verify serviceability by measuring the mechanical, pneumatic, hydraulic, or electrical characteristics with prescribed standards.

c. Service. Operations required periodically to keep an item in proper operating condition, i.e., to clean (includes decontaminate, when required), to preserve, to drain, to paint, or to replenish fuel, lubricants, chemical fluids, or gases.

d. Adjust. To maintain or regulate, within prescribed limits, by bringing into proper or exact position, or by setting the operating characteristics to specified parameters.

e. Align. To adjust specified variable elements of an item to bring about optimum and desired performance.

f. Calibrate. To determine and cause correction to be made or to be adjusted on instruments or test, measuring, and diagnostic equipments used in precision measurement. Consists of comparisons of two instruments, one of which is a certified standard of known accuracy, to detect and adjust any discrepancy in the accuracy of the instrument being compared.

g. Remove/Install. To remove and install the same item when required to perform service or other maintenance function. Install may be the act of emplacing, seating, or fixing into position a spare, repair part, or module (component or assembly) in a manner to allow the proper functioning of an equipment or system.

h. Replace. To remove an unserviceable item and install a serviceable counterpart in its place. "Replace" is authorized by the MAC and is shown as the 3rd position code on the SMR code.

i. Repair. The application of maintenance services, including fault location/troubleshooting, removal/installation, and disassembly/assembly procedures and maintenance actions to identify troubles and restore serviceability to an item by correcting specific damage, fault malfunction or failure in a part, subassembly, module (component or assembly), end item, or system.

j. Overhaul. That maintenance effort (service/action) prescribed to restore an item to completely serviceable/ operational condition as required by maintenance standards in appropriate technical publications (i.e., DMWR). Overhaul is normally the highest degree of maintenance performed by the Army. Overhaul does not normally return an item to like new condition.

k. Rebuild. Consists of those services/actions necessary for the restoration of unserviceable equipment to a like new condition in accordance with original manufacturing standards. Rebuild is the highest degree of material maintenance applied to Army equipment. The rebuild operation includes the act of returning to zero those age measurements (hour/miles, etc., considered in classifying Army equipment/components).

D-6. THE ARMY MAINTENANCE SYSTEMS (TAMS).

a. The Army maintenance system consist of four

levels. They are unit, direct support, general support, and depot levels of maintenance.

b. The Maintenance Allocation Chart (MAC) will be the primary tool for assigning tasks within the levels of the Army Maintenance System.

D-6.1. UNIT LEVEL MAINTENANCE.

a. Unit maintenance tasks are performed by the operator, crew, and/or unit maintenance personnel. Equipment operators and unit mechanics use PMCS to detect and correct faults.

b. Maintenance operations assigned to the unit level normally include the following: (1) Performance of PMCS.

(2) Inspection by sight and touch of external and other easily accessible components.

(3) Lubrication, cleaning, preserving (to include spot painting), tightening, replacement, and minor adjustments.

(4) Replacement of easily accessible unserviceable parts and assemblies usually not requiring special tools or test equipment.

(5) Replacement of modules as authorized by the Maintenance Allocation Chart.

c. Unserviceable reparables (properly preserved, protected, and tagged) that are beyond authorized capability or capacity to repair will be evacuated through the appropriate supply support activities for repair or exchange.

d. Performance of unit level maintenance will be documented using the forms and records defined in DA PAM 738-750 and DA PAM 738-751. This information will assist commanders in evaluating and monitoring their maintenance program.

e. Material condition status readiness reporting will be per AR 700-138.

D-6.2. DIRECT SUPPORT MAINTENANCE.

a. Direct support is characterized by:

(1) One stop service to supported units.

(2) Highly mobile, weapon system oriented maintenance.

b. Direct Support Maintenance Divisional Maintenance units will support organic elements of the division. Attached units will require coordination with parent unit for support. Non-divisional maintenance units will provide support on an area basis and back-up support to divisional support units.

c. Direct support units will be the primary reentry point for unserviceable, repairable Class IX material to the supply support activity.

d. Operations assigned to direct support normally include the following:

(1) Repair of unserviceable repairables in support of Supply Support Activities (SSA) authorized to operate repairable exchange facilities.

(2) Repair of unserviceable economically repairable end item per MACs. This will be repair and return to user.

(3) Provision of proactive material readiness and technical assistance to unit maintenance elements including

- (a) Visits to supported units on a regular basis.
- (b) Advice to supported units in proper methods for performing maintenance and related logistic support.
- (c) Coordination with supported units to perform technical inspection when requested.
- (d) On-site assistance to supported units.

(4) Diagnosis and isolation of material of module malfunctions, adjustment, and alignment of modules that can be readily competed with assigned tools and TMDE.

(5) Performance of light body repairs to include straightening, welding, sanding, and painting of skirts, fenders, body, and hull sections when required to stop corrosion to retain structural integrity.

(6) Evacuation of unserviceable end items to designated maintenance facilities when repair is beyond authorized capability or authority.

(7) Evacuation of recoverability Code H, D, and L unserviceable repairable components to supporting supply activity.

(8) Requesting back-up support from other direct support and general support units as required.

D-6.3. GENERAL SUPPORT MAINTENANCE.

a. General support maintenance is characterized by

(1) Commodity oriented repair of components and end items in support of the theater supply system.

(2) Back-up maintenance support to direct support units.

(3) Job shop/bay or production line operations with the capability to task organize to meet special mission requirements.

(4) Location at echelons above corps.

b. General support units selected by MACOMS and approved by HQDA (DALO-SMP) may be given the authority to repair selected items identified by the maintenance Code "D" (Depot) or "L" (specialized repair activity) in Maintenance Allocation Charts. Requests for SRA approval will include specifics as to what equipment the SRA will repair, the time period the unit will perform D or L repair and a cost benefit analysis.

c. Operations assigned to general support level normally include the following: (1) Diagnosis, isolation and repair of faults within modules/components per MACs.

(2) Repair of selected LRUs and PCBS per the MACs.

(3) Performance of heavy body, hull, turret and frame repair per MACs.

(4) Area maintenance support, to include technical assistance and on-site maintenance as required or requested.

(5) Collection and classification of Class VII material (less aircraft, ammunition, missiles, cryptographic and medical material) for proper disposition.

(6) Operation of Cannibalization points, when authorized by MACOM Commanders (AR 710-2).

(7) Evacuation of unserviceable end items and components, through the appropriate supply activity.

(8) Fabrication or manufacture of repair parts, assemblies, components, jigs, and fixtures when approved by the MACOM.

(9) Request for back-up support as required.

D-6.4. DEPOT LEVEL MAINTENANCE.

a. Detailed policy and guidance for depot level maintenance is in AR 750-2.

b. Depot level maintenance supports both the combat forces and the Army supply system.

(1) Depot level maintenance provides technical support and back-up to direct support and general support units. A joint decision is required between the Theater Army (TA) Commander and Commander AMC to determine the relationship of AMC supply and maintenance activities with the Theater Commander in peacetime.

(2) In wartime the Theater Commander

assumes control of depot level maintenance operations in the Theater of operations.

(3) Depot level maintenance provides combat ready material to the Army supply system.

c. Depot level maintenance is performed by TDA industrial type activities operated by the Army. Depot level maintenance may also be performed by contract, ISA, and interdepartmental or interagency agreement or lower levels of maintenance when authorized.

Section II. MAINTENANCE ALLOCATION CHART

(1) GROUP NUMBER	(2) COMPONENT ASSEMBLY	(3) MAINTENANCE FUNCTION	(4) MAINTENANCE CATEGORY					(5) TOOLS AND EQUIPMENT	(6) REMARKS
			C	O	F	H	D		
22	Body, Chassis, & Hull								
2202	Accessory Items								
	Accessory Item								
	Asphalt Hose	Inspect	0.1					1	
		Replace		0.5					
2210	Data Plates								
	Instruction Plates	Inspect	0.1					1	
		Replace		0.5					
	Caution Plates	Inspect	0.1					1	
		Replace		0.5					
	Data Plates	Inspect	0.1					1	
		Replace		0.5					
31	Basic Issue Items								
3100	Basic Issue Items								
	Extractor, Barrel	Inspect	0.1						
		Repair			0.5				1
	Ram, Barrel	Inspect	0.1						
		Repair			0.5				1
47	Gauges (non-electrical), Weighing and Measuring Devices								
4702	Gauges, Mountings, Lines, & Fittings								
	Thermometer	Inspect	0.1					1	
		Replace		0.5					
73	Concrete & Asphalt Equipment Component								
7312	Feeder or Conveyor Discharge								
	Dedrumming Tunnel	Inspect	0.1					1, 2	
		Service		0.2					
MAINTENANCE LEVELS:									
C - OPERATOR/CREW = UNIT			F - DIRECT SUPPORT			D - DEPOT			
O - ORGANIZATIONAL = UNIT			H - GENERAL SUPPORT						

Section II. MAINTENANCE ALLOCATION CHART

(1) GROUP NUMBER	(2) COMPONENT ASSEMBLY	(3) MAINTENANCE FUNCTION	(4) MAINTENANCE CATEGORY					(5) TOOLS AND EQUIPMENT	(6) REMARKS	
			C	O	F	H	D			
7312 Cont'd	Dedrumming Tunnel Cont'd Loading Platform	Replace		4.0	4.0					
		Repair								
	Discharge Chute	Inspect	0.1					1		
		Replace		3.0						
	Tunnel Doors	Repair		0.5				1		
		Inspect	0.1							
	Rainshields	Replace		0.2						
		Repair		0.5						
	7318	Tanks, Valves, Formed Hoses, Lines, Fittings Valves	Inspect	0.1					1	
			Replace		1.0					
7320	Hot Oil Piping	Inspect	0.1					1		
		Replace		1.5						
7320	Storage Tank	Inspect	0.1					1,2	2	
		Service			2.0					
7320	Heater Coils	Replace			4.0					
		Inspect	0.1					1,2	2	
7320	Boom and Attaching Parts Hoist	Replace	1.0							
		Inspect	0.1					1,2		
7320	Controller	Replace		0.1		2.0				
		Repair								
7320	Trolley	Inspect	0.1					1		
		Replace		1.0						
7320	Trolley	Repair		1.0						
		Inspect	0.1							
7320	Trolley	Replace		0.2						
		Repair		0.3						
MAINTENANCE LEVELS:										
C - OPERATOR/CREW = UNIT			F - DIRECT SUPPORT			D - DEPOT				
O - ORGANIZATIONAL = UNIT			H - GENERAL SUPPORT							

Section II. MAINTENANCE ALLOCATION CHART

(1) GROUP NUMBER	(2) COMPONENT ASSEMBLY	(3) MAINTENANCE FUNCTION	(4) MAINTENANCE CATEGORY					(5) TOOLS AND EQUIPMENT	(6) REMARKS
			C	O	F	H	D		
7320 Cont'd	Winch	Inspect Replace Repair	0.1	0.3 0.5					
MAINTENANCE LEVELS: C - OPERATOR/CREW = UNIT O - ORGANIZATIONAL = UNIT F - DIRECT SUPPORT H - GENERAL SUPPORT D - DEPOT									

**SECTION III TOOL AND TEST EQUIPMENT REQUIREMENTS
FOR
ENCODER-DECODER KY-883/GSC**

TOOL OR TEST EQUIPMENT REF CODE	MAINTENANCE CATEGORY	NOMENCLATURE	NATIONAL/NATO STOCK NUMBER	TOOL NUMBER
		UNLESS OTHERWISE NOTED, ALL MAINTENANCE FUNCTIONS CAN BE ACCOMPLISHED WITH THE TOOLS CONTAINED IN THE FOLLOWING COMMON TOOL SETS.		
1	O, F, H	Shop Equip Ord Repair, Lt Truck MTD - (SC4940-97-CL-E04)	4940-00-294-9516	T13152
1	O, F, H	Tool Kit (Auto) Maint, Org Maint	4910-00-754-0654	W32593
1	O, F, H	Tool Kit (Auto) Maint, Org Maint Common #2 - (SC4910-95-CL-A72)	4910-00-754-0650	W32720
1	O, F, H	Tool Kit, Light Weight (SC51 80-90-CL-N26)	5180-00-177-7033	W33004
1	O, F, H	Shop Equip (Ato) Maint & Repair, Org Maint Supp #1 (SC491 0-95-CL-A73)	4910-00-754-0653	W32867
2	F, H	Shop Equip, Contract Maint TRK MTD - (SC4940-97-CL-E05)	4940-00-294-9518	T10138
2	F, H	Shop Equip Gen Purp Repair Semitrailer MTD (SC4940-97-CL-E03)	4940-00-287-4894	T10549
2	F, H	Tool Kit, Master Mechanic Equip Maint & Repair (SC5180-90-CL-N05)	5180-00-699-5273	W45060
2	F, H	Shop Set, Fuel & Elec Sys Field Maint Basic Spp #2 (SC491 0-95-CL-A65)	4910-00-390-7775	T30688
2	F, H	Shop Equip Machine Shop Field Maint Basic Supp #2 (SC491 0-95-CL-A02)	3470-00-754-0708	T15644
2	F, H	Measuring & Layout Tool Set, Mach - (SC5280-95-CL-A02)	5280-00-511-1950	W44512
2	F, H	Shop Equip Welding Field Maint (SC3470-95-CL-A08)	3470-00-357-7268	T16714

Section IV. REMARKS

(1) Reference Code	(2) Remarks
1	Refer to Appendix G for make from instructions.
2	Check with local Safety Office for confined space entry requirements. They must test atmosphere with a calibrated direct reading instrument for oxygen content, flammable gases and vapors and potential toxic air contaminants.
3	Unit maintenance is authorized to replace/repair the lower hook assembly and load chain, and to replace the safety latch on both the upper and lower hooks. Refer to Appendix A for Unit authorized parts.

D-9 (D-10 Blank)

APPENDIX E - PREVENTIVE MAINTENANCE CHECKS & SERVICES

Table E-1. OPERATOR, CREW PREVENTIVE MAINTENANCE CHECKS AND SERVICES FOR MELTER, ASPHALT SKID MOUNTED HOT OIL CIRCULATING

ITEM NO.	INTERVAL	LOCATION		PROCEDURE	NOT FULLY MISSION CAPABLE IF:
		ITEM TO CHECK/SERVICE			
				<p style="text-align: center;">NOTE</p> <p>Perform Weekly as well as Before operation if:</p> <p>1. You are the assigned operator and have not operated the Melter since the last weekly PMCS.</p> <p>2. You are operating the Melter for the first time.</p> <p style="text-align: center;">WARNING</p> <p style="text-align: center;">Operating the equipment when it is wet could cause the asphalt to boil and catch on fire. The results could cause serious bodily injury or death.</p>	
1.	Before	General		a. Visually check inside tunnel and storage tank for moisture. If present, dry before operation.	Class III leaks are detected.
	Before			b. Visually check for damaged piping or hoses.	
	Before/			c. Visually check for evidence of fluid leakage.	
	During			d. Inspect heat transfer oil and asphalt piping for proper connections.	
2.	Before	Controls and Instruments		a. Visually inspect thermometer for damage and loose mounting.	Broken or missing.
	During			b. Periodically observe thermometer for proper operating temperature. (200-250 Degrees F Normal Operation)	
	Before/			c. Check valves for leakage or	Class III leak is detected.
	During			damage and proper operation.	

Table E-1. OPERATOR, CREW PREVENTIVE MAINTENANCE CHECKS AND SERVICE FOR MELTER, ASPHALT SKID MOUNTED HOT OIL CIRCULATING - Continued

ITEM NO.	INTERVAL	LOCATION	PROCEDURE	NOT FULLY MISSION CAPABLE IF:
		ITEM TO CHECK/SERVICE		
3	Before/	Asphalt Transfer Hoses	Inspect for loose connections, breaks and leaks.	Class III leak is detected.
4.	During De-Drumming Tunnel Doors		Inspect for damage and proper operation.	Door fails to close properly.
5.	Before		a. Check brake for evidence of Brake slips. slippage.	Control malfunctions.
	Before		b. Check control functions for proper operation.	
	Before		c. Inspect hooks for damage, cracks, twists, excessive throat opening, latch engagement and latch operation.	
6.	Before		d. Check individual chain links for wear.	Chain twists.
	Before/		e. Check load chain for proper reeving and for chain twisting.	
	During Hand Winch	Check for lubrication of threads of handle.		
7.	Melter Tank After	Insure all asphalt was pumped from tank and asphalt piping was emptied.		

Table E-2. ORGANIZATIONAL PREVENTIVE MAINTENANCE CHECKS AND SERVICES FOR MELTER, ASPHALT SKID MOUNTED HOT OIL CIRCULATING Location

ITEM NO.	INTERVAL	LOCATION	PROCEDURE	NOT FULLY MISSION CAPABLE IF:
		ITEM TO CHECK/SERVICE		
1.	Monthly	Fluid Lines, Fittings and Valves	a. Visually inspect for leaks, breaks, loose mountings and connections. b. Check valves for operation.	
2.	Monthly	De-Drumming Tunnel Doors	Visually inspect for damage and proper operation of doors.	
3.		Heating Coils	Monthly Open de-drumming tunnel doors and visually inspect the coils for damage.	
4.	Monthly	Melter Tank	Visually inspect tank for leaks.	
5.	Monthly	Melter Tank Cleaning	Notify Direct Support Maintenance to clean tank as required IAW instructions in paragraph 4-1.	
6.	Yearly	Electric Chain Hoist	a. Inspect all external parts for loose screws, bolts or nuts. b. Inspect lift wheel and hook block for bright shiny area appearing on wear surfaces. c. Check electrical cords and cables for damaged insulation. d. Inspect trolley trackwheels for external wear on tread and flange. Replace worn trackwheels that show a flat wear area greater than 1/4 inch across or trackwheels that no longer rotate freely. e. Adjust armature brake for 0.020-0.030 inch gap.	

APPENDIX F
COMPONENTS OF END ITEM (COEI)
and
BASIC ISSUE ITEMS LIST (BIIL)
Section I. INTRODUCTION

F-1. SCOPE.

This appendix lists components of the end item and basic issue items for the Asphalt Melter to help you inventory the items for safe and efficient operation of the equipment.

F-2. GENERAL.

The Components of End Item (COEI) and Basic Issue Items (BIIL) Lists are divided into the following sections:

a. Section II, Components of End Item. This listing is for information purposes only, and is not authority to requisition replacements. These items are part of the Asphalt Melter. As part of the end item, these items must be with the end item whenever it is issued or transferred between property accounts. Items of COEI are removed and separately packaged for transportation or shipment only when necessary. Illustrations are furnished to help you find and identify the items.

b. Section III, Basic Issue Items. These essential items are required to place the Asphalt Melter in operation, operate it, and to do emergency repairs. Although shipped separately packaged, BIIL must be with the Asphalt Melter during operation and when it is

transferred between property accounts. This list is your authority to request/requisition them for replacement based on authorization of the end item by the TOE/MTOE. Illustrations are furnished to help you find and identify the items F-3. EXPLANATION OF COLUMNS.

a. Column (1), Illus Number, gives you the number of the item illustrated.

b. Column (2), National Stock Number, identifies the stock number of the item to be used for requisitioning purposes.

c. Column (3), Description and Usable On Code, identifies the Federal item name (in all capital letters) followed by a minimum description when needed. The last line below the description is the Commercial and Government Entity Code (CAGEC) (in parentheses) and the part number.

d. Column (4), U/I (unit of issue), indicates how the item is issued for the National Stock Number shown in column two.

e. Column (5), Qty Rqd, indicates the quantity required.

Section II. COMPONENTS OF END ITEM

Not applicable.

Section III. BASIC ISSUE ITEMS

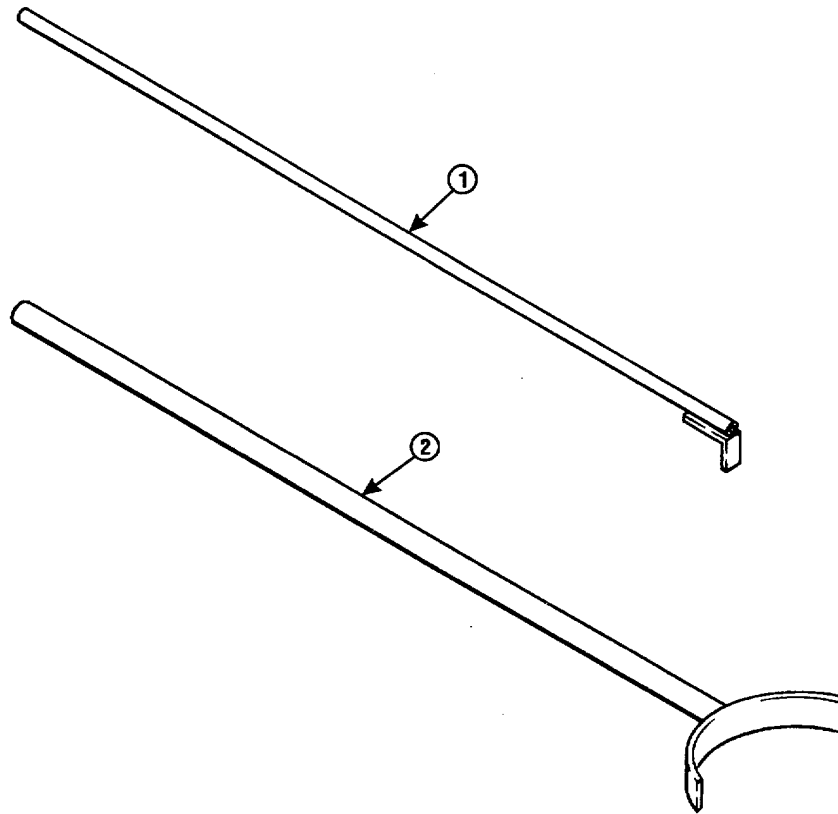

(1) Illus Number	(2) National Stock Number	(3) Description CAGEC and Part Number	(4) U/M	(5) Qty Rqd
BARREL 2	1 EA.....	(11740) 3000-143 RAM, BARREL (11740) 3000-142	1 EA	EXTRACTOR, 1

**APPENDIX G
ILLUSTRATED LIST OF MANUFACTURED ITEMS**

NOTE: All dimensions shown are in inches.

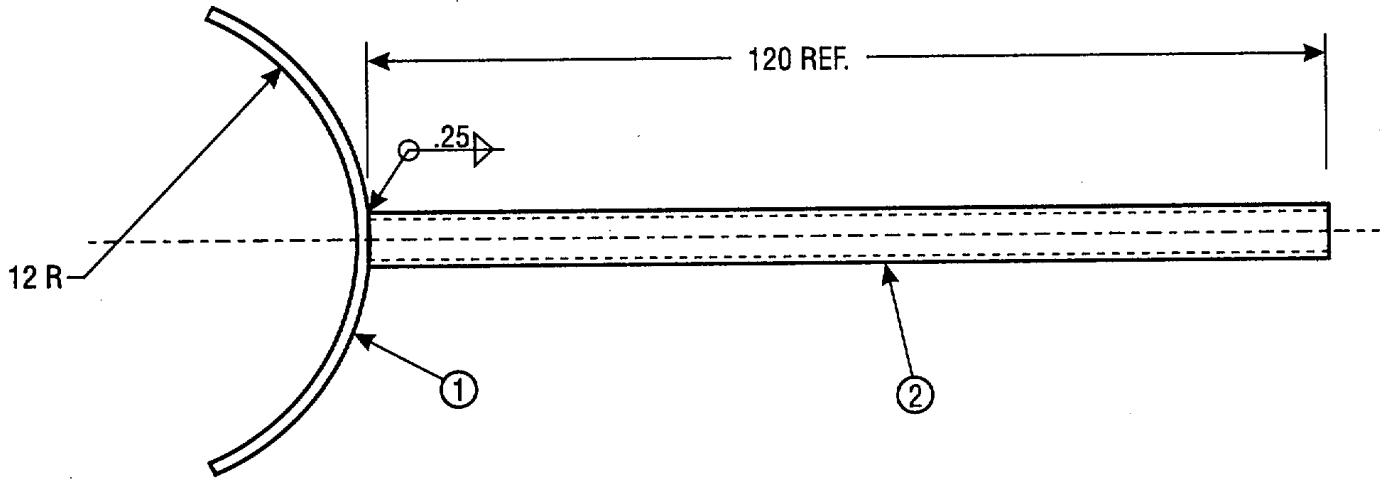

RAM, BARREL - Part Number 3000-142 (CAGEC 11740)

ITEM NO.	NATIONAL STOCK NUMBER	DESCRIPTION	QTY
1		BAR, METAL: 1/4 x 2 cut to 18 inches long, part number QQT570, CAGEC 81348	1
2	5975-00-178-1218	CONDUIT: 1" x 10' 1	

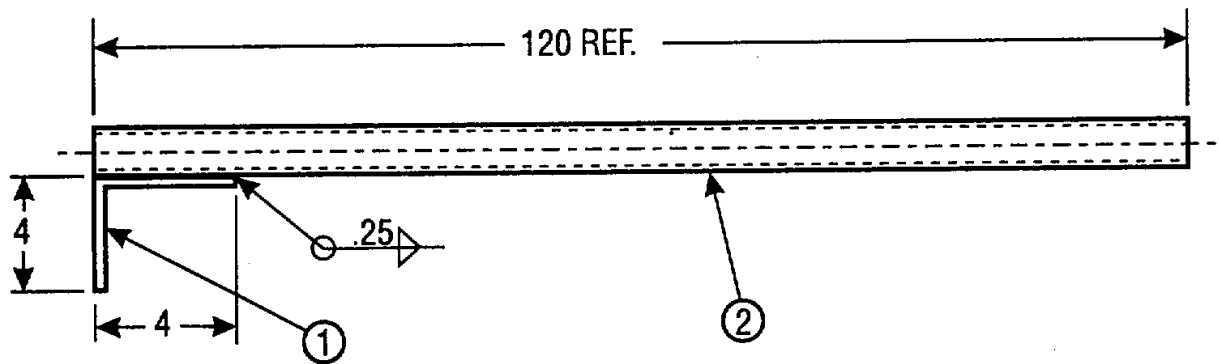

EXTRACTOR, BARREL - Part Number 3000-143 (CAGEC 11740)

ITEM NO.	NATIONAL STOCK NUMBER	DESCRIPTION	QTY
1	9510-00-189-1553	BAR, METAL: 1/4 x 1 cut to 8 inches long	1
2	5975-00-178-1216	CONDUIT, METAL, RIGID: 1/2"x 10'	1

By Order of the Secretary of the Army:

DENNIS J. REIMER
General, United States Army
Chief of Staff

Official:



JOEL B. HUDSON

Acting Administrative Assistant to the
Secretary of the Army

01474

Distribution:

To be distributed in accordance with DA Form 12- 25-E (Block 5773) Operator's, Unit, Direct Support and General Support maintenance requirements for TM5-3895-368-14&P.

* U.S. GOVERNMENT PRINTING OFFICE: 1996 746-014/20158

RECOMMENDED CHANGES TO EQUIPMENT TECHNICAL PUBLICATIONS



THEN... JOT DOWN THE DOPE ABOUT IT ON THIS FORM, CAREFULLY TEAR IT OUT, FOLD IT AND DROP IT IN THE MAIL!

SOMETHING WRONG WITH THIS PUBLICATION?

FROM: (PRINT YOUR UNIT'S COMPLETE ADDRESS)

DATE SENT

PUBLICATION NUMBER

PUBLICATION DATE

PUBLICATION TITLE

BE EXACT... PIN-POINT WHERE IT IS

PAGE NO.

PARA-GRAPH

FIGURE NO.

TABLE NO.

IN THIS SPACE TELL WHAT IS WRONG AND WHAT SHOULD BE DONE ABOUT IT:

TEAR ALONG PERFORATED LINE

PRINTED NAME, GRADE OR TITLE, AND TELEPHONE NUMBER

SIGN HERE:

DA FORM 2028-2
1 JUL 79

PREVIOUS EDITIONS ARE OBSOLETE.

P.S.—IF YOUR OUTFIT WANTS TO KNOW ABOUT YOUR RECOMMENDATION MAKE A CARBON COPY OF THIS AND GIVE IT TO YOUR HEADQUARTERS.

THE METRIC SYSTEM AND EQUIVALENTS

WEIGHT MEASURE

1 Centimeter = 10 Millimeters = 0.01 Meters = 0.3937 Inches
 1 Meter = 100 Centimeters = 1000 Millimeters = 39.37 Inches
 1 Kilometer = 1000 Meters = 0.621 Miles

WEIGHTS

1 Gram = 0.001 Kilograms = 1000 Milligrams = 0.035 Ounces
 1 Kilogram = 1000 Grams = 2.2 lb.
 1 Metric Ton = 1000 Kilograms = 1 Megagram = 1.1 Short Tons

LIQUID MEASURE

1 Milliliter = 0.001 Liters = 0.0338 Fluid Ounces
 1 Liter = 1000 Milliliters = 33.82 Fluid Ounces

SQUARE MEASURE

1 Sq. Centimeter = 100 Sq. Millimeters = 0.155 Sq. Inches
 1 Sq. Meter = 10,000 Sq. Centimeters = 10.76 Sq. Feet
 1 Sq. Kilometer = 1,000,000 Sq. Meters = 0.386 Sq. Miles

CUBIC MEASURE

1 Cu. Centimeter = 1000 Cu. Millimeters = 0.06 Cu. Inches
 1 Cu. Meter = 1,000,000 Cu. Centimeters = 35.31 Cu. Feet

TEMPERATURE

$5/9(^{\circ}\text{F} - 32) = ^{\circ}\text{C}$
 212° Fahrenheit is equivalent to 100° Celsius
 90° Fahrenheit is equivalent to 32.2° Celsius
 32° Fahrenheit is equivalent to 0° Celsius
 $9/5^{\circ}\text{C} + 32 = ^{\circ}\text{F}$

APPROXIMATE CONVERSION FACTORS

TO CHANGE	TO	MULTIPLY BY
Inches	Centimeters	2.540
Feet	Meters	0.305
Yards	Meters	0.914
Miles	Kilometers	1.609
Square Inches	Square Centimeters	6.451
Square Feet	Square Meters	0.093
Square Yards	Square Meters	0.836
Square Miles	Square Kilometers	2.590
Acres	Square Hectometers	0.405
Cubic Feet	Cubic Meters	0.028
Cubic Yards	Cubic Meters	0.765
Fluid Ounces	Milliliters	29.573
its	Liters	0.473
arts	Liters	0.946
allons	Liters	3.785
Ounces	Grams	28.349
Pounds	Kilograms	0.454
Short Tons	Metric Tons	0.907
Pound-Feet	Newton-Meters	1.356
Pounds per Square Inch	Kilopascals	6.895
Miles per Gallon	Kilometers per Liter	0.425
Miles per Hour	Kilometers per Hour	1.609

TO CHANGE	TO	MULTIPLY BY
Centimeters	Inches	0.394
Meters	Feet	3.280
Meters	Yards	1.094
Kilometers	Miles	0.621
Square Centimeters	Square Inches	0.155
Square Meters	Square Feet	10.764
Square Meters	Square Yards	1.196
Square Kilometers	Square Miles	0.386
Square Hectometers	Acres	2.471
Cubic Meters	Cubic Feet	35.315
Cubic Meters	Cubic Yards	1.308
Milliliters	Fluid Ounces	0.034
Liters	Pints	2.113
Liters	Quarts	1.057
ers	Gallons	0.264
ms	Ounces	0.035
ograms	Pounds	2.205
Metric Tons	Short Tons	1.102
Newton-Meters	Pounds-Feet	0.738
Kilopascals	Pounds per Square Inch	0.145
ometers per Liter	Miles per Gallon	2.354
ometers per Hour	Miles per Hour	0.621



PIN: 070721-000